

DAVIS 

DriveRight[®] 600

User's Guide

Product # 8156GD, 8156HD, 8156VSS & 8156VF

One Year Limited Warranty

We warrant our products to be free of defects in material and workmanship for one year from date of original purchase. We make every effort to carefully manufacture our products to the highest standards of quality. Occasionally, however, parts may be missing, defective, or damaged.

If you have a defective part, please call 1-510-732-7814 for authorization before returning the item for repair or replacement. Upon receiving authorization, return the product to us, shipping charges prepaid. Include proof of purchase and a written explanation of the problem. During the warranty period, we will, at our option, either repair or replace the product free of charge.

This warranty does not cover damage due to improper installation or use, negligence, accident, unauthorized service, or the incidental or consequential damages beyond the Davis products themselves. Implied warranties are limited in duration to the life of this limited warranty. Some states do not allow limitations on how long an implied warranty lasts, or the exclusion or limitation of incidental and consequential damages, so the above limitations may not apply to you. This warranty gives you specific legal rights. You may have other rights, which vary from state to state.

FCC Part 15 Class B Registration Warning

This equipment has been tested and found to comply with the limits for a Class B digital device, pursuant to Part 15 of the FCC Rules. These limits are designed to provide reasonable protection against harmful interference in a residential installation. This equipment generates, uses, and can radiate radio frequency energy and, if not installed and used in accordance with the instructions, may cause harmful interference to radio communications.

However, there is no guarantee that interference will not occur in a particular installation. If this equipment does cause harmful interference to radio or television reception, which can be determined by turning the equipment on and off, the user is encouraged to try to correct the interference by one or more of the following measures:

- Reorient or relocate the receiving antenna.
- Increase the separation between the equipment and receiver.
- Connect the equipment into an outlet on a circuit different from that to which the receiver is connected.
- Consult the dealer or an experienced radio/TV technician for help.

Changes or modifications not expressly approved in writing by Davis Instruments may void the user's authority to operate this equipment.

Product Numbers: 8156GD, 8156HD, 8156VSS & 8156VF

Davis Instruments Part Number: 7395.192

Rev. A Manual (September 6, 2002)

© Davis Instruments Corp. 2002. All rights reserved.

This product complies with the essential protection requirements of the EC EMC Directive 89/336/EC.

DriveRight is a registered trademark of Davis Instruments Corp. Windows is a trademark of Microsoft Corporation.

TABLE OF CONTENTS

INTRODUCTION TO THE DRIVERIGHT 600	1
A Note About the Concept of “Trips“	1
A Word About Safe Use	1
DriveRight Vehicle Management Software	2
USING THE DRIVERIGHT 600	3
Using the Four Buttons	3
The Data Screens	4
The Settings Screens	5
Changing Units of Measure	6
CALIBRATING THE DRIVERIGHT 600	6
Calibrating from the Software (VSS Only)	6
Calibration Using the Speedometer	7
Calibration Using the Odometer	10
DATA SCREENS	11
Current Readings Screen	12
Driver ID Code Entry & Digital Input Status Screen	13
Driver ID Code	14
Two Digital Inputs	15
Activity Indicator	15
Trip Start/End Log Screen	15
Trip Speed and Distance Log Screen	16
Trip Acceleration/Deceleration Log Screen	17
GPS Latitude and Longitude Position Screens	18
Odometer Screen	19
Limits Screen	19
SETTINGS SCREENS	20
Last Correct Security Code Entry Screen	20
Security Code Screen	20
Clear Log Screen	22
Alarm On/Off Screen	23
Calibration Screen	23
Limit and Unit Settings Screen	23
Time Entry	24
Date Entry	25
Year Entry	26

MISCELLANEOUS INFORMATION	26
Accident Log	26
Tamper Log	26
Battery Operation	27
Battery Life	29
Display Lamp	29
Restarting the DriveRight 600	29
TROUBLESHOOTING GUIDE	30
Contacting Davis Technical Support	32
TECHNICAL SPECIFICATIONS	33

INTRODUCTION TO THE DRIVERIGHT 600

The DriveRight 600, in conjunction with the DriveRight Vehicle Management Software, provides advanced vehicle safety and use monitoring capabilities as well as comprehensive fleet management capabilities. This manual explains how to use the DriveRight 600 display unit to view information.

NOTE: *Altering the DriveRight 600's limits, deleting trip information, and calibrating the DriveRight 600 require entry of a security code before changes may be made.*

A Note About the Concept of “Trips“

Much of the data stored and displayed by the DriveRight 600 is stored and displayed by “trip.” For example, you may view the maximum speed or the time spent driving over the set speed limit during a single trip. You may page back and forth through all of the trips stored in the DriveRight 600's memory.

Stored in the DriveRight 600 is a “trip stop time” which represents the amount of time for which the vehicle must be stopped before the DriveRight 600 ends the current trip. The default trip stop time is 5 minutes (this setting may be altered using the DriveRight Vehicle Management Software). Whenever the vehicle is *not in motion* for an amount of time equal to the trip stop time, the DriveRight 600 saves the current trip data to memory and begins a new trip (this new trip will remain blank until the vehicle begins moving again).

NOTE: *The DriveRight 600 also saves the current trip data whenever a driver “logs out” (see “Driver ID Code Entry & Digital Input Status Screen” on page 13).*

A Word About Safe Use

It goes without saying that you should never attempt to change the DriveRight 600 display while you are driving. Safe driving requires extreme attentiveness. Changing the DriveRight 600 display while driving may result in dangerous distraction. Only use the unit when you are not operating your vehicle.

In addition, always warn drivers about the DriveRight 600's alarms. If an alarm sounds, a driver who has not been warned may be startled or get distracted trying to trace the source of the noise. In either case, it may create a safety concern, so warn drivers in advance.

DriveRight Vehicle Management Software

The DriveRight Vehicle Management Software enables more detailed tracking of vehicle usage and access to some additional features of the DriveRight 600. The following is a list of the DriveRight 600 features which may only be accessed using the software.

- View information contained in the “accident log”**
- View tamper information**
- Enter or change the odometer reading or the odometer reading’s unit of measure**
- Set login alarm**
- Set trip stop time**
- Up to 100 download-authorized driver codes.**
- View trip type information**
Although you may specify the type of trip using the DriveRight 600 display unit, you must have the software to view trip type information.
- Configure GPS**
Requires optional DriveRight 600 GPS module, #8157.

USING THE DRIVERIGHT 600

This section briefly describes the use of the DriveRight 600 display unit. The use of the four buttons (PLUS, MINUS, MODE, SET/CLEAR) and the sequence of data screens and settings screens is explained. Descriptions of the information and options available from each screen are explained separately in “Data Screens” starting on page 11 and “Settings Screens” starting on page 20.

Using the Four Buttons

The DriveRight 600 has four buttons: PLUS, MINUS, MODE, and SET/CLEAR. The general use of each button is explained briefly below:

❑ PLUS/MINUS

When a digit or segment (e.g., MPH or KPH) is flashing, use the PLUS and MINUS keys to scroll forward or backward (respectively) through the available options (usually 0 to 9).

When viewing any logged trip information screen, use the PLUS and MINUS keys to page forward or backward (respectively) through the stored trips.

❑ SET/CLEAR

When entering codes or setting limits, the flashing digit/segment indicates what will change if PLUS or MINUS is pressed. Pressing and releasing SET/CLEAR causes the next digit/segment to begin flashing.

From the Driver ID Code screen, press and hold SET/CLEAR (for at least 2 seconds) to “log out.” The driver ID code is reset to 0000.

❑ MODE

Press and release MODE to move to the next data or information screen.

Press and hold MODE to switch between the group of data screens and the group of settings screens.

When the unit is in sleep mode, press MODE to “wake” the unit up.

The Data Screens

The data screens enable you to view most of the information stored by the DriveRight 600. To cycle through the data screens (in the order shown below), press and release MODE.

NOTE: To view the settings screens, press and hold MODE until the Last Correct Security Code Entry screen appears.

NOTE: The GPS Latitude and Longitude screens are not displayed if the DriveRight console is not connected to a vehicle.

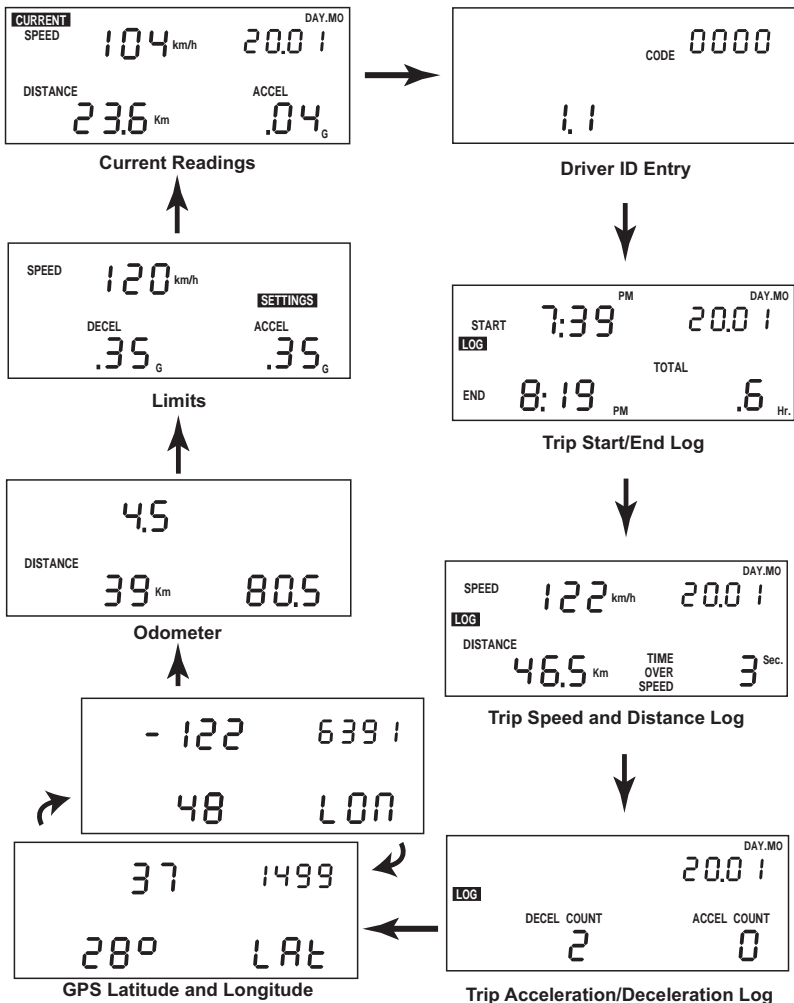

DriveRight 600 Data Screens

The Settings Screens

To access the settings screens, press and hold MODE while viewing any of the data screens. After a few seconds, the Security Code screen will appear. To cycle through the settings screens (in the order shown below), press and release MODE.

NOTE: To view the data screens, press and hold MODE until the Current Readings screen appears.

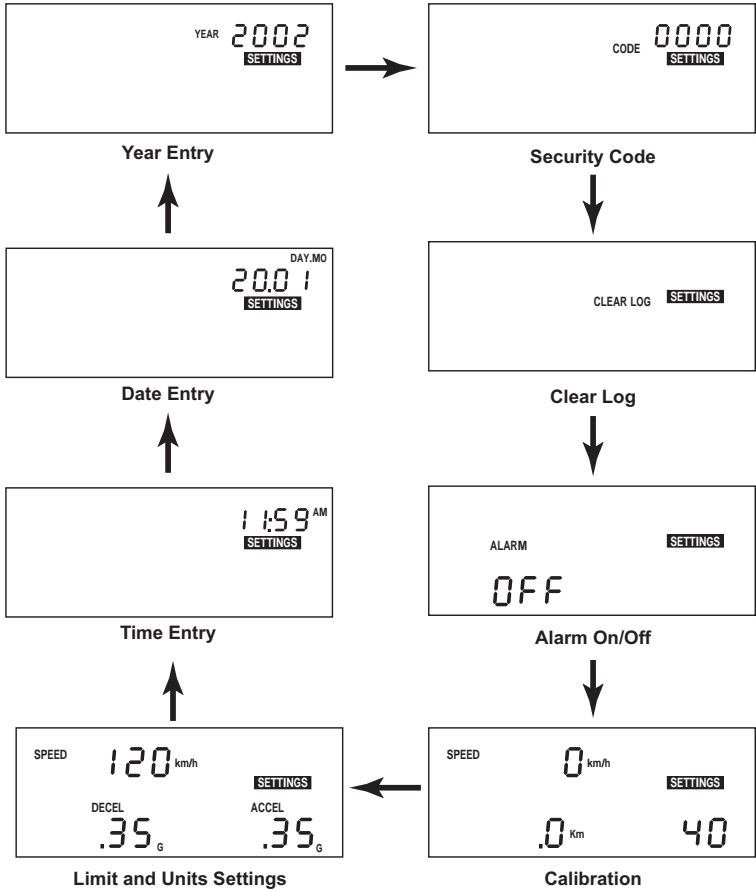

DriveRight 600 Settings Screens

Changing Units of Measure

To change units of measure, press and hold SET/CLEAR for at least 2 seconds while viewing the Current Readings screen. You may also change units from the Limit and Units Settings screen by pressing SET/CLEAR unit either the km/h or MPH segment is flashing, and then pressing PLUS to toggle between the two units of measure.

You may change the date display format from the Date Entry screen and the time display format from the Time Entry screen

CALIBRATING THE DRIVERIGHT 600

You must calibrate the unit before it will report the correct speed distance, deceleration, and acceleration. Calibration adjusts the unit to work properly with your vehicle's VSS signal or with the vehicle's differential and tire size.

Calibrating from the Software (VSS Only)

If you have the DriveRight Vehicle Management Software and a VSS DriveRight 600, you may quickly and accurately calibrate the unit using the software, provided you know the pulses per mile used by your vehicle's VSS (vehicle speed sensor). Contact your dealer's service department for the necessary information.

- 1. Install the DriveRight Vehicle Management Software.**

- 2. Connect the DriveRight 600 to your computer.**

Consult the documentation supplied with the software for instructions.

- 3. Start the DriveRight Vehicle Management Software.**

- 4. Choose Set DriveRight from the DriveRight menu.**

The Set DriveRight dialog box opens. You will see a VSS Pulse button within this dialog box.

5. Choose the VSS Pulse button.

The Calibration dialog box appears.

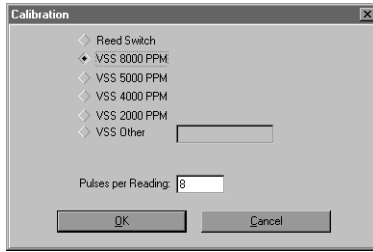

Calibration Dialog Box

6. Choose the correct VSS PPM setting from the list. Do not change the Pulse per Reading setting.

7. Choose OK to close the Calibration dialog box.

8. If desired, use the Set DriveRight dialog box to change any other desired settings (limits, time, date, year, alarms, etc.).

Consult the software documentation for instructions.

9. When finished, choose OK to close the Set DriveRight dialog box.

The software will prompt you to indicate whether you want to change the setting on the DriveRight 600.

10. Choose Yes.

The software will calibrate the DriveRight 600 and make any other necessary changes.

Calibration Using the Speedometer

In order to calibrate using the speedometer, you must drive steadily at 40 km/h (25 MPH) and press a button on the DriveRight 600. The DriveRight 600 bases its calibration on the speed of the vehicle at the moment of calibration which it assumes to be 40 km/h (25 MPH). Because of the nature of this calibration procedure, we strongly recommend that it be performed by two people: one to drive the vehicle and one to operate the DriveRight 600.

NOTE: *If you have entered a security code, you will need to enter that code before the DriveRight 600 will allow access to the calibration screen.*

1. Press and hold MODE to access the settings screens.

2. Press and release MODE until the Calibration screen appears.

The calibration speed (40 or 25) appears at the bottom right of the display. The uncalibrated speed reading appears at the top of the display, along with the unit of measure (km/h or MPH). Note that until you calibrate the DriveRight 600 this speed reading will be inaccurate. The distance, which appears in the lower left of the display, is not necessary for this calibration procedure.

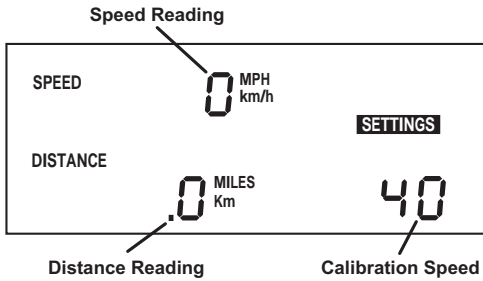

Calibration Screen

3. Drive the vehicle until you reach 40 km/h (25 MPH) and keep the vehicle steady at that speed.

4. Once the vehicle is moving steadily at the calibration speed, press and hold SET/CLEAR.

The word CAL appears in the top right of the display when you press SET/CLEAR. This indicates that the unit is in the process of calibrating.

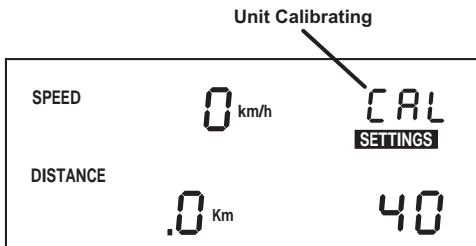

Unit Calibrating

5. **Continue to hold SET/CLEAR until the unit beeps and the word “DONE” appears on the display.**

This indicates that the unit has finished calibrating. The speed reading at the top of the display will also change so that it reads much closer to your speedometer’s reading.

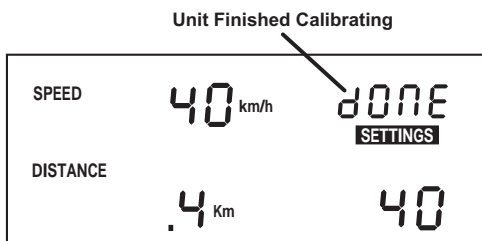

Unit Finished Calibrating

6. **Once the calibration is complete, drive the vehicle and compare the vehicle’s speedometer to the DriveRight 600’s speed display.**
Be aware that the DriveRight 600 responds to changes in speed faster than most vehicles’ speedometers. To accurately compare, you must drive steadily at a speed for a short time.
7. **If necessary, “fine tune” the calibration by pressing PLUS or MINUS.**
Each time you press PLUS or MINUS, the DriveRight 600 speed reading adjusts up or down. Depending on the speed of the vehicle and the calibration, you may or may not see a change in the speed reading in the calibration screen each time you press the button.
8. **Continue to Press PLUS or MINUS until the DriveRight 600’s speed reading agrees with your vehicle’s speedometer at a variety of speeds.**
9. **When finished calibrating, press and hold MODE until you return to the data screen.**

When you finish fine-tuning, press MODE to exit the calibration screen. All information will be automatically saved. *Do not press and hold SET/CLEAR in an effort to save the fine-tuned calibration!* If you press and hold SET/CLEAR, the unit completely resets the calibration number. Data Screens.

Calibration Using the Odometer

In order to calibrate using the odometer, you must compare a distance reading taken from your vehicle's odometer to the DriveRight 600 and adjust the DriveRight 600 to match the vehicle's odometer. Depending on how far you drive in order to calibrate the unit, this can result in an extremely accurate calibration.

NOTE: *We recommend that you drive a minimum of 32km (20 miles) when calibrating the unit.*

Your vehicle's speedometer and odometer may not be perfectly linked. If they differ and you calibrate your DriveRight 600 using the vehicle's odometer, you may notice a discrepancy between the DriveRight 600's speed readings and the vehicle's speedometer.

- 1. Obtain a rough calibration, using the speedometer as described in "Calibration Using the Speedometer" on page 7.**
- 2. Reset your vehicle's trip meter to zero or make a note of the odometer reading.**
- 3. Make sure you have a new trip started on the DriveRight 600 (i.e., the distance travelled is 0.**
To forcibly start a new trip, log out (see page 14 for details).
- 4. Drive the vehicle for at least 32 km (20 miles).**
The further you drive, the more accurate your calibration.
- 5. When you finish driving, compare your vehicle's trip meter reading to the distance travelled reading on the DriveRight 600.**
At this point, what you will need to do is increase or decrease the distance measured by the DriveRight 600 until it agrees with your vehicle's odometer reading. This is accomplished from the calibration screen.
- 6. Press and hold MODE to access the settings screens.**
- 7. Press and release MODE until the Calibration screen appears.**
The distance travelled appears at the lower left of the display. Note that until you calibrate the DriveRight 600, this distance reading will be inaccurate. The speed reading and calibration speed, which appear on the display as well, are not necessary for this calibration procedure.

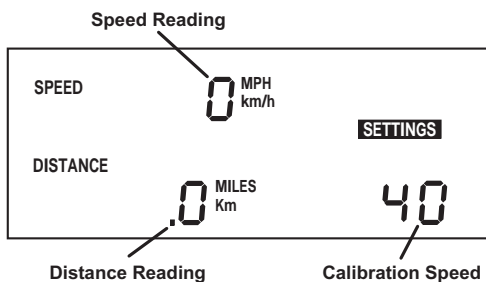

Calibration Screen

8. **Press PLUS or MINUS until the distance reading matches the trip meter on your vehicle.**

Depending on how many miles you drove, you may need to press PLUS or MINUS several times before the distance reading changes.

NOTE: *Pressing and holding PLUS/MINUS down increases the rate at which the DriveRight 600 adjusts the distance reading.*

9. **When finished calibrating, press and hold MODE until you return to the data screen.**

Press MODE to exit the calibration screen. All information will be automatically saved. *Do not press and hold SET/CLEAR in an effort to save the fine-tuned calibration!* If you press and hold SET/CLEAR, the unit completely resets the calibration number.

DATA SCREENS

The following section explains all the information and options available in the various data screens. In addition to the options listed in the individual sections below, in every screen you have the following two options:

- Move to the next Data Screen**
Press and release MODE.
- View the Settings Screens**
Press and hold MODE.

Current Readings Screen

The current readings screen displays constantly updating (as long as the car is moving) speed, distance (for the current trip), and acceleration/deceleration readings (acceleration is positive, deceleration is negative). The current date (or time) is also displayed on this screen.

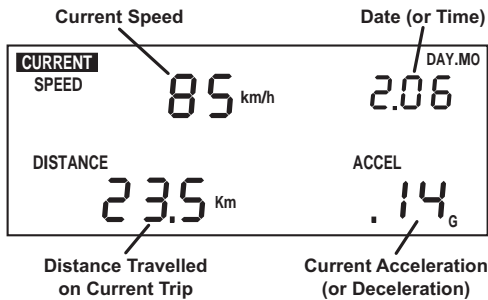

Current Readings Screen

You have the following options from the Current Readings Screen:

- Toggle Between Date and Time Display**
You may display either the date or the time. To toggle between the two, press and release SET/CLEAR.
- Change Units of Measure**
To change the units of measure in which data is displayed from metric to U.S. units (or vice versa), press and hold SET/CLEAR for approximately 2 seconds. This does not change the date or time display format.
- Specify Trip Type**
There are four types of trips stored by the DriveRight 600: Business, Personal, Commute, and Other. The trip type is stored along with the rest of the trip information and is automatically saved when information is downloaded using the software. Although you may specify the type of trip using the DriveRight 600 display unit, you must have the software to view trip type information.

To change the type of trip, press and hold MINUS. The trip type screen will appear--do not release MINUS.



Trip Type Screen

As long as you hold MINUS, the DriveRight 600 will cycle through the letters representing the various trip types: b = Business, P = Personal, C = Commute, O = Other. Release MINUS when the desired trip type appears.

NOTE: *You may change the trip type anytime during a trip. Trip type information is saved when the trip ends.*

Turn Display Lamp On/Off

To turn the DriveRight 600's display lamp on or off, press PLUS. You must be viewing the Current Readings Screen to turn the display lamp on and off.

Driver ID Code Entry & Digital Input Status Screen

The Driver ID Code Entry Screen enables you to enter the driver ID code, displays the status of the two digital inputs, and also includes an activity indicator for the reed switch (GD and HD models) or VSS input (VSS and VF models).

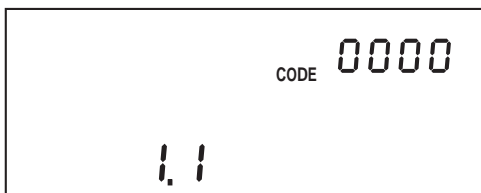

Driver ID Code Entry Screen

Driver ID Code

When using the DriveRight 600 to monitor the driving of multiple drivers, assign each driver a unique 4-digit ID code. Before driving the vehicle, the driver must enter his or her ID code. The DriveRight 600 stores the driver ID code with the rest of the trip information, which enables you to view information for each individual driver. In addition, data downloaded by the software is segregated by driver ID code, enabling detailed tracking of multiple drivers.

The DriveRight Vehicle Management Software allows you to use the driver ID code to track locations instead when a single driver is using a vehicle. You may also use the software to turn on an alarm which will alert the driver when a driver ID (or location ID) has not been entered.

NOTE: *Driver ID code 0000 (four zeros) is used to view information for the vehicle (all drivers) and should not be assigned to any driver, unless only a single driver uses the vehicle.*

In addition to marking data as belonging to a particular driver, the driver ID code may be used when viewing information on the display to filter the information being viewed. To view information for one specific driver, enter that driver's ID code in this screen. The DriveRight 600 display will filter out any data not assigned that code. The Driver Performance Score will be calculated using only data assigned that code as well.

To view all information, regardless of driver ID code, enter the reserved code: 0000.

You have the following options from the Driver ID Code Entry Screen:

Enter a Driver ID Code

The flashing digit in the code is the active digit. Press and release PLUS or MINUS to cycle forward or backward through the available entries for the active digit (0 to 9). To change the digit which is active, press and release SET/CLEAR. Each time you press SET/CLEAR, the next digit become active.

If you have loaded driver ID codes into the DriveRight 600, then only those codes will be accepted. A "no" will appear on the screen if a wrong ID code is entered. A code of "0" will still be accepted.

❑ Log Out

To “log out” press and hold SET/CLEAR for 2 seconds, until the code resets to 0000. As soon as a driver logs out, the current trip is ended and data for that trip stored in the DriveRight 600’s memory. Note that you may not log out when the vehicle is in motion.

Two Digital Inputs

Two digital inputs allow you to track the operation of lights or electrically powered accessories on the vehicle. A typical application would be to monitor the headlights and the brakes. The screen displays “1” if the input is on, and “0” if the input is off. The status of the inputs is stored in the trip log.

Activity Indicator

Primarily useful for troubleshooting the installation, the small “dot” between the two activity indicators will appear whenever the reed switch used with the 1856GD and 1856HD models is open, or whenever the VSS input used with the 1856VSS and 1856VF models is high. The reed switch closes once each time the vehicles drive shaft rotates.

Trip Start/End Log Screen

The Trip Start/End Log Screen shows the start and end time for each trip currently stored in the DriveRight 600’s memory. To view trip times for a specific driver, enter that driver’s ID code in the Driver ID Code Entry screen. To view all trip times for the vehicle, enter ID code 0000.

NOTE: If the end time for a trip is “dashed,” it means that you are viewing the current trip, which has not yet ended (unless the unit was restarted in the middle of a trip).

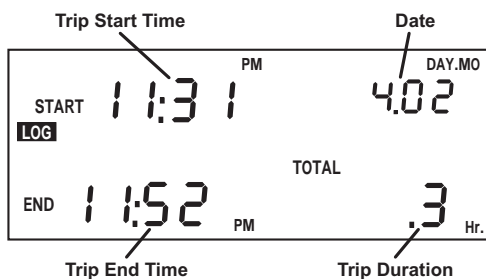

Trip Start/End Log Screen

You have the following options from the Trip Start/End Log Screen:

- Page Through Stored Trip Information**
Press MINUS to page backward through stored trip information. Press PLUS to page forward through stored trip information. Hold the button down to increase the speed at which the DriveRight 600 pages. When you reach the first or last stored trip, the DriveRight 600 will no longer page in that direction.

Trip Speed and Distance Log Screen

The Trip Speed and Distance Log Screen shows the maximum speed, distance travelled, and amount of time spent driving over the set speed limit for each trip currently stored in the DriveRight 600's memory. To view trip speed and distance information for a specific driver, enter that driver's ID code in the Driver ID Code Entry screen. To view all trip speed and distance information for the vehicle, enter ID code 0000.

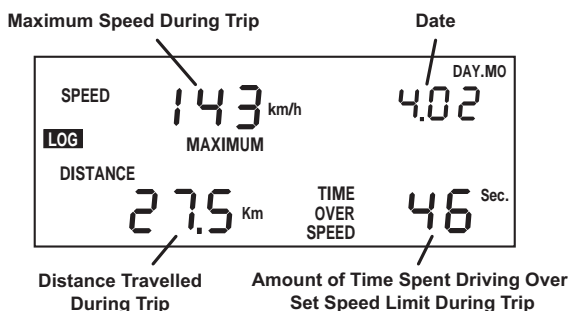

Trip Speed and Distance Log Screen

You have the following options from the Trip Speed and Distance Log Screen:

- Toggle Between Driver ID Code and Date Display**
You may display either the current Driver ID code or the date. To toggle between the two, press and release SET/CLEAR.
- Page Through Stored Trip Information**
Press MINUS to page backward through stored trip information. Press PLUS to page forward through stored trip information. Hold the button down to increase the speed at which the DriveRight 600 pages. When you reach the first or last stored trip, the DriveRight 600 will no longer page in that direction.

Trip Acceleration/Deceleration Log Screen

The Trip Acceleration/Deceleration Log Screen shows the number of times the set acceleration and deceleration limits were exceeded during each trip currently stored in the DriveRight 600's memory. (Each time the limit is exceeded, 1 "count" is recorded, regardless of the amount of time for which the limit was exceeded.) To view trip acceleration/deceleration information for a specific driver, enter that driver's ID code in the Driver ID Code Entry screen. To view all trip acceleration/deceleration information for the vehicle, enter ID code 0000.

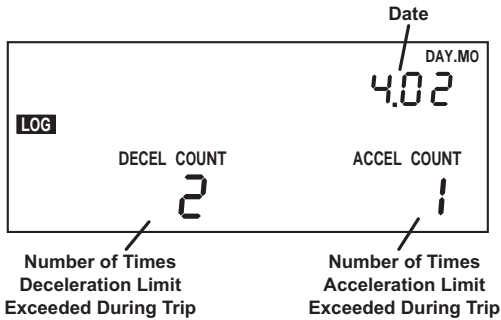

Trip Acceleration/Deceleration Log Screen

You have the following options from the Trip Acceleration/Deceleration Log Screen:

- Toggle Between Driver ID Code and Date Display**
You may display either the current driver ID code or the date. To toggle between the two, press and release SET/CLEAR.
- Page Through Stored Trip Information**
Press MINUS to page backward through stored trip information. Press PLUS to page forward through stored trip information. Hold the button down to increase the speed at which the DriveRight 600 pages. When you reach the first or last stored trip, the DriveRight 600 will no longer page in that direction.

GPS Latitude and Longitude Position Screens

The GPS Position Screens alternate between Latitude and Longitude to show your current position, speed, and direction.

NOTE: The GPS screens are not displayed if the DriveRight is not connected to a vehicle.

NOTE: The GPS may take up to several minutes to start tracking a new trip, depending on the overhead obstructions surrounding the vehicle.

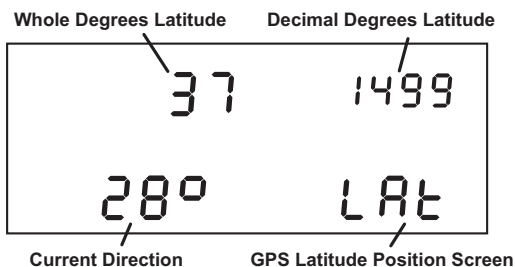

Latitude Screen

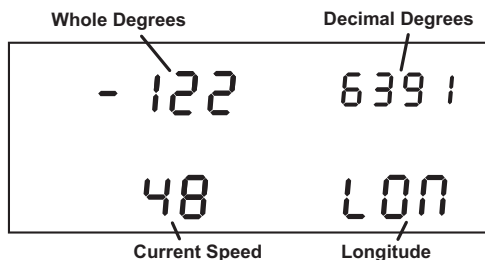

Longitude Screen

A “NO” on the Latitude and Longitude screens indicates the GPS module is not able to track your current position. The last known position will be displayed.

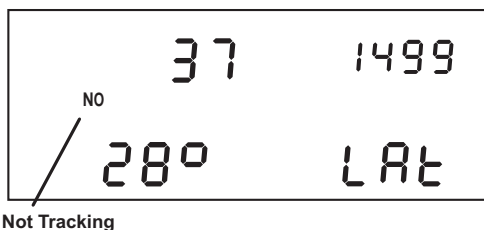

Not Tracking Indicator

Odometer Screen

The Odometer screen displays the vehicle's odometer reading which must be set from the DriveRight Vehicle Management Software. The odometer reading is spread across the two digit registers at the bottom of the screen and may take some getting used to (the odometer reading in the screen shown below is 5,812.2 km).

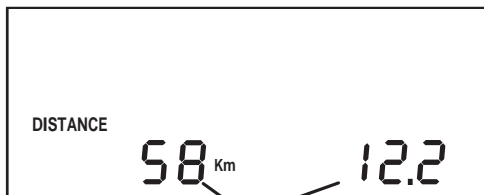

Odometer Reading (5,812.2 km)

Odometer Screen

NOTE: The odometer readings is ALWAYS shown in the unit of measure in which it was entered. To change the unit of measure, you need to reenter the odometer reading using the software.

Limits Screen

The Limits screen enables you to view the set speed, acceleration, and deceleration limits for this DriveRight 600 unit. You may not change any of the limits from this screen; limits may only be changed from the Limits and Units Setting screen (see "Time Entry" on page 24), or using the DriveRight Vehicle Management Software.

Acceleration and deceleration is measured in "G's" (the gravitational constant which represents the acceleration of an object when falling to earth in a vacuum). 1G is roughly equal to an acceleration of 35 km/h (22 MPH) per second.

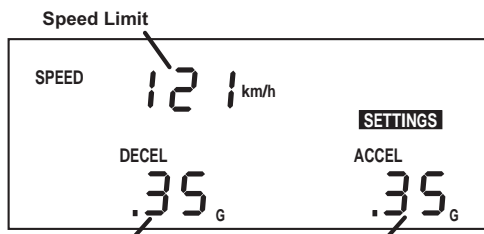

Deceleration Limit

Acceleration Limit

Limit Settings Screen

SETTINGS SCREENS

The following section explains all the information and options available in the various settings screens. In addition to the options listed in the individual sections below, in every screen you have the following two options:

- Move to the next Settings Screen**
Press and release MODE.
- View the Data Screens**
Press and hold MODE.

Last Correct Security Code Entry Screen

The DriveRight 600 records the date and time that a correct code was last entered. This screen allows you to detect if someone learns the code and uses it to access the settings screens or simply to determine the last time you entered the correct code.

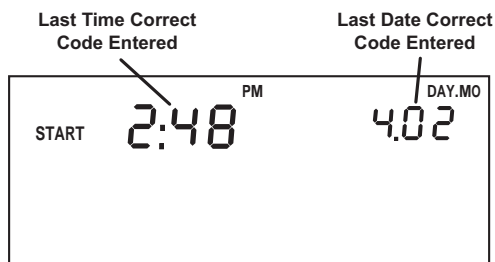

Last Correct Security Code Entry Screen

Security Code Screen

If you are concerned about unauthorized changing of DriveRight 600 settings, you may enter a security code from the DriveRight Vehicle Management Software. The DriveRight 600 will not allow access to the rest of the settings screens until the correct 4-digit security code is entered. The unit allows five attempts to enter the correct security code before returning to the Current Readings screen and activating the tamper indicator (pressing MODE to move to the next settings screen is considered an "attempt"). The time and date of the unsuccessful tamper attempt is stored and may be viewed using the DriveRight Vehicle Management Software.

NOTE: Use security code 0000 (four zeros) if you do not want to password-protect calibration, since the unit defaults to that code when first displaying the Security Code screen.

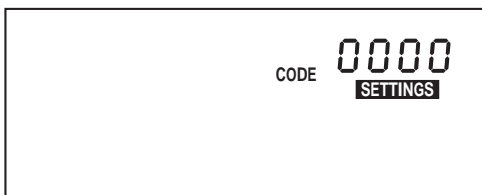

Security Code Screen

You have the following options from the Security Code Screen:

Enter the Security Code

The flashing digit in the code is the active digit. Press and release PLUS or MINUS to cycle forward or backward through the available entries for the active digit (0 to 9). To change the active digit, press and release SET/CLEAR. Each time you press SET/CLEAR, the next digit becomes active. Once the correct security code has been entered, press MODE to move to the next settings screen.

NOTE: If the entered code is correct, the clear all log data screen appears when you press MODE. If the entered code is not correct, the word NO appears on the display. You may attempt to enter the correct code five times before the unit returns you to the Current Readings screen and activates the tamper indicator.

Set or Change the Security Code

Use PLUS and MINUS to enter your current code (if you are entering a security code for the first time, make sure 0000 is entered). Press and hold SET/CLEAR until the word CHG (change) appears on the display.

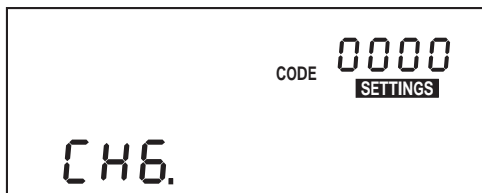

Change Security Code

Use PLUS and MINUS to enter the desired security code. When finished, press MODE to save the new code and move to the Clear Log Screen.

Clear Log Screen

The clear all log data screen allows you to perform a “total clear” function which erases all data for every trip in your log at once.

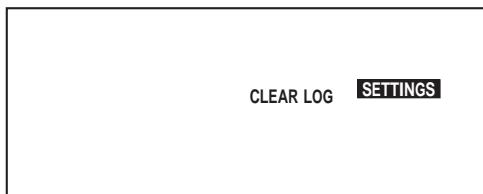

Clear Log Screen

You have the following option from the Clear Log Screen:

Clear all Log Data

Press and hold SET/CLEAR. The word CLR (clear) appears in the display to indicate that the unit is preparing to clear all log data. To protect against accidental clearing of data, you must press and hold SET/CLEAR for 3 seconds before the unit clears data.

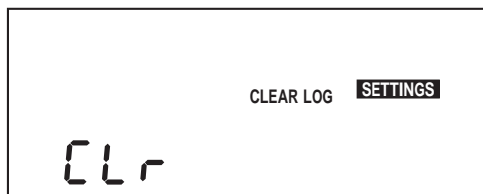

Preparing to Clear Log Data

Continue to hold SET/CLEAR until the unit beeps and the word CLR disappears from the display. This indicates that the unit is in the process of clearing data. The unit beeps and the word DONE appears in the display when the unit finishes clearing data.



Unit Finished Clearing Data

Alarm On/Off Screen

The Alarm On/Off screen enables you to toggle the DriveRight 600's audible alarm on and off. When the alarm is on, the unit will beep when any of the set limits is exceeded, as a warning to the driver. Turning the alarm off will disable the beeping, though the DriveRight 600 will continue to record violations of the set limits.

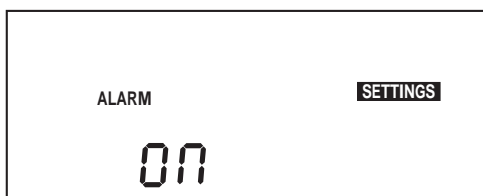

Alarm On/Off Screen

You have the following option from the Alarm On/Off Screen:

Toggle the Alarm Setting

To toggle the alarm setting from On to Off (or vice versa), press and release SET/CLEAR. Each time you press SET/CLEAR, the display changes to read ON or OFF, depending on the alarm's status.

Calibration Screen

The Calibration screen enables you to calibrate the DriveRight 600 for your vehicle. See "Calibrating the DriveRight 600" on page 6 for details.

Limit and Unit Settings Screen

The Limit and Unit Settings screen allows you to set limits for speed, acceleration, and deceleration. You may also change the unit of measure in which speed and distance information is displayed (km/h or MPH).

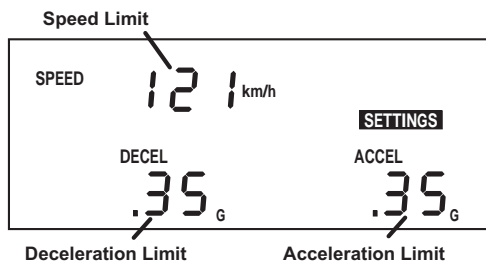

Limit Entry Screen

You have the following options from the Limit and Unit Settings Screen:

Enter/Change a Limit

Use SET/CLEAR to change the active digit and use PLUS and MINUS to enter the desired limit. for speed, acceleration, and deceleration.

NOTE: *The maximum limit settings are as follows:
Speed 255, Acceleration and Deceleration
2.55.*

Change the Unit of Measure

Press and release SET/CLEAR until the display segment (km/h or MPH) is flashing. Use PLUS and MINUS to toggle between km/h and MPH. Whatever segment is displayed when you press MODE to exit this screen is the unit of measure in which speed and distance information will be displayed.

Time Entry

The Time Entry screen allows you to set the time and to select the format (12 hour or 24 hour) in which you want time displayed.



Time Entry Screen

You have the following options from the Time Entry Screen:

Set the Time

Use PLUS and MINUS to set the time. If you are displaying time in the 12 hour format, remember to choose either AM or PM. To do this, follow the same procedure as if you were changing the format of the time display, as explained below.

Change the Time Display Format

Press and release SET/CLEAR until the PM, AM, or 24HR segment is flashing. Press PLUS to cycle through the three possible options: PM, AM, and 24HR. When the desired option appears in the display, stop. The segment displayed when you press MODE to exit this screen sets the format in which time will be displayed.

NOTE: *The unit will not automatically convert the time from 12 hour to 24 hour or vice versa. You must enter the time in the new format yourself.*

Date Entry

The Date Entry screen allows you to set the date and to select the format (Day.Month or Month:Day) in which you want the date displayed.



Date Entry Screen

You have the following options from the Date Entry Screen:

Set the Date

Use PLUS and MINUS to set the date.

Change the Time Display Format

Press and release SET/CLEAR until the Mo:Day or Day.Mo segment is flashing. Press PLUS to toggle between the two segments. When the desired format appears in the display, stop. The segment displayed when you press MODE to exit this screen sets the format in which the date will be displayed.

Year Entry

The Year Entry screen allows you to enter the correct year. Setting the year is not essential to unit operation, however, if you enter the correct year, the unit will automatically adjust for leap years.

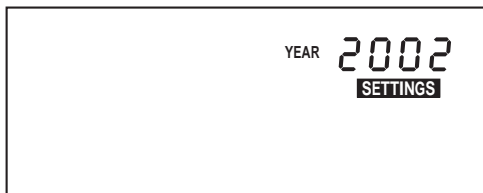

Year Entry Screen

You have the following option from the Year Entry Screen:

- Set the Year**
Use PLUS and MINUS to set the Year.

MISCELLANEOUS INFORMATION

Accident Log

The DriveRight 600 has room in memory for 10 “accident” logs which show the vehicle’s speed for the 20 seconds before and after a sudden deceleration. Information is written to the “accident” log any time the vehicle exceeds the unit’s set deceleration limit. The information in the accident log may be downloaded, viewed, printed, and stored using the DriveRight Vehicle Management Software.

NOTE: *The unit always keeps the last 20 seconds of vehicle speed in memory. This information may be viewed using the software also.*

Tamper Log

The DriveRight 600 will alert you if anyone attempts to tamper with the unit, provided that you have entered a security code other than 0000. The following actions will be logged as a tamper attempt:

- The DriveRight 600 is unplugged (loses power)**
- Five incorrect entries in a row for the Security Code**
- DriveRight is plugged back into the car (Tamper is logged but not displayed on the console)**
- DriveRight is rebooted**

When a tamper is logged, the word “TAMPER” appears on all screens. Plus, the time at which the tamper attempt occurred and the cause of the tamper is stored in the tamper log. The last 10 tamper events can be downloaded, viewed and printed, using the DriveRight Vehicle Management Software.

To clear the flashing TAMPER segment, enter the correct security code (see “Security Code Screen” on page 20). The tamper indicator is also cleared after data is downloaded.

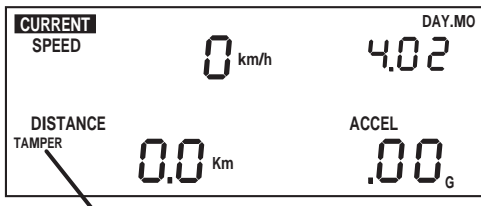

Tamper Indicator Flashing

Tamper Indicator (Current Readings Screen)

NOTE: All data in the DriveRight 600 is stored in “non-volatile” memory which means that even if power is removed, no data will be lost.

Battery Operation

The DriveRight 600 is designed to be taken out of your vehicle so the data may be reviewed anywhere. If you disconnect the unit from its power source (the vehicle) it will automatically switch to battery power. The word BAT appear in the lower left corner of all screens to indicate that you are running on battery power.

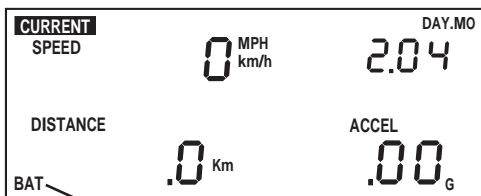

Battery Indicator

Battery Power Indicator

NOTE: If you notice that the LCD is fading when running on battery power, it means your battery power is low. You should replace your battery as soon as possible.

To install a new battery, insert the battery as shown below.

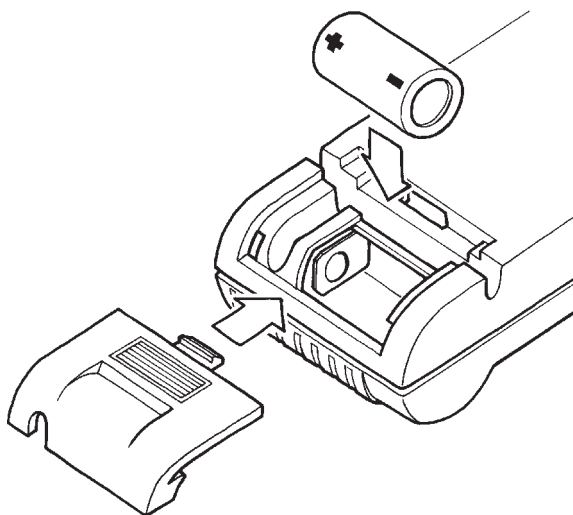

Installing the Battery

When operating under battery power, the unit will undergo a few changes in operation in order to conserve battery power:

- If you go more than 5 minutes without pressing a button, the unit enters “sleep mode.”**
In sleep mode, all but the most essential unit functions (that is, time and date) shut down. The display goes blank and no data is recorded when the unit is “asleep.”

NOTE: *The unit never goes into sleep mode when connected to your vehicle (i.e., receiving power from your vehicle’s battery).*

To “wake up” the unit, press MODE or reconnect the unit to your vehicle so it receives power from your vehicle’s battery.

- The unit cannot record data.**
This means the unit is in “sleep mode” because it is not connected to the vehicle and does not receive power from the vehicle’s battery. Thus if you do not power the DriveRight 600 from your vehicle’s battery, it will not record any data.
- The display lamp is disabled.**
You cannot turn on the unit’s display lamp.

- ❑ **The GPS Latitude and Longitude position screen is not displayed.**

The Latitude and Longitude screen will not appear when you scroll through the DriveRight 600 data screens.

Battery Life

When removed from a vehicle, the DriveRight unit taps into its own battery for power (instead of relying on the vehicle's battery). On the unit's battery alone, a unit will operate for *260 hours* or, in sleep mode for *4 months*.

The life of the unit's battery depends on your download schedule. For example, if you take the unit out of the vehicle 5 days a week, 8 hours a day, the unit's battery can last up to 16 months. In that situation, because not all out-of-vehicle time will be spent in sleep mode and because of the occasional delay in returning the unit to the vehicle, we recommend replacing the battery every year. If at any time the LCD display begins dimming, the battery is low and due for replacement.

If you plan to store a unit out-of-vehicle for more than a week, we recommend removing the battery. When you replace the battery, data and settings are not lost but you will need to reset the date and time.

Display Lamp

To read the DriveRight 600 at night, use the display lamp. To toggle the display lamp on and off, press PLUS when viewing the Current Readings screen. Be aware that the display lamp does not work when the unit is operating on battery power.

NOTE: *The display lamp automatically shuts itself off after 10 minutes if the vehicle is stopped.*

Restarting the DriveRight 600

If DriveRight 600 display "locks up," you may restart the DriveRight 600 by pressing and releasing MODE and PLUS at the same time. No log data, settings, or code information is lost when you restart the unit.

NOTE: *The tamper indicator will appear if you restart the unit in this way, provided you use a security code other than 0000.*

If the DriveRight 600 is still locked up, you must remove and reinsert the battery and reset the time.

TROUBLESHOOTING GUIDE

While the DriveRight 600 is designed to provide years of trouble-free operation, occasional problems may arise. If you are having a problem with your unit, please check the following guide before calling the factory. You will be able to solve many of the problems yourself. If, after checking this guide, you are still unable to solve the problem, please call the factory at 1-510-732-7814 for further instructions. You may also check the support section of our website (www.davisnet.com) or send e-mail to tech support (support@davisnet.com).

Please do not return your unit for repair without prior authorization.

Many of the troubleshooting suggestions below relate to the positioning of the magnet and sensor in driveshaft mounted DriveRight 600 units. If you have a VSS version, you should ignore these suggestions.

NOTE: *We will be glad to answer any questions you may have regarding the operation of the Drive-Right unit itself. We cannot, however, answer any questions relating to the installation of the unit in your vehicle.*

- I can't turn my lamps off.**
Make sure you are in the current readings screen when you hit +.
- When operating on batter power, the LCD segments are faint.**
Battery power is low. Replace the battery (see "Battery Operation" on page 27).
- The BAT segment is on when the unit is plugged into the car.**
The unit is not getting primary power (from the vehicle's battery). Check the fuse in the power line for your car.
- My buzzer is faint or not audible when the unit is operating on battery power.**
This is normal.
- My DriveRight 600 and my speedometer do not agree.**
From the calibration screen, use the PLUS and MINUS keys to fine-tune the calibration.

NOTE: *The DriveRight 600 responds to changes in speed faster than most speedometers.*

- ❑ **My speed is intermittently reading zero while driving.**

This could be one of two things. First, make sure the speed sensor is within 10-16 mm (3/8" - 5/8") of the magnet. If it is, make sure the installed speed sensor protrudes at least 20 mm (3/4") from the bracket.
- ❑ **My speed reads zero while driving.**

There could be a number of things wrong. Make sure the DriveRight 600 is plugged in. Make sure the DriveRight 600 is calibrated. Make sure the speed sensor is within 10-16 mm (3/8" - 5/8") of the magnet. Make sure the unit is not running on battery power (see "Battery Operation" on page 27). If it is check the fuse in the power line. If all of this fails to solve the problem, consult the trouble shooting section of your Installation Guide.
- ❑ **The speed reading on the DriveRight 600 agrees with my vehicle's speedometer, but the distance reading on the DriveRight 600 and my odometer differ (or vice versa).**

For best accuracy, you should calibrate using the car's odometer (see "Calibration Using the Odometer" on page 10). You may readjust the unit's calibration periodically (to maintain accuracy) use the PLUS and MINUS buttons to readjust the distance reading to match the vehicle's trip meter reading after a long trip.
- ❑ **The DriveRight 600 seems to be recording erroneous readings at low speeds.**

Excessive mechanical vibrations at low speeds can cause erroneous readings. Have your installation checked if you have this problem.
- ❑ **The DriveRight 600 indicates erroneous decelerations at low speeds (VSS models only).**

On some cars, the wrong dip switch settings can cause the DriveRight 600's speed reading to abruptly drop to zero at around 10 to 13 mph, which generates an erroneous deceleration log. Check your VSS cable dip switch settings if you have this problem.

- The display is black or all the segments appear to be on.**
The display was left in direct sunlight. The display will return when it cools down. Even though the display is black, the DriveRight 600 continues to record data.
- The tamper light won't go off.**
Enter your security code (see "Tamper Log" on page 26).
- I've forgotten my secret code.**
If you have the software, you can read the vehicle's code. Otherwise, ship the unit back to us with a check for \$25.00 and a note explaining the situation. We will return the unit to you with the code set to 0000.

Contacting Davis Technical Support

If you have questions, or encounter problems installing or operating your DriveRight 600, please contact Davis Technical Support. Most questions can be answered while you're on the phone. Sorry, we are unable to accept collect calls.

NOTE: *Please do not return items to the factory for repair without prior authorization.*

- (510) 732-7814 – Monday through Friday, 7:00 a.m. to 5:30 p.m. Pacific Time.**
- (510) 670-0589 – Fax to Technical Support.**
- support@davisnet.com – E-mail to Technical Support.**
- info@davisnet.com – E-mail to Davis Instruments.**
- www.davisnet.com – Copies of User Manuals are available on the "DriveRight Support" page. Watch for FAQs and other updates.**

TECHNICAL SPECIFICATIONS

Speed	Displays current speed in MPH or km/h. Records maximum speed for each trip Records total time in which speed exceeded set limit for each trip Accuracy: $\pm 1\%$
Acceleration and Deceleration	Displays current acceleration in g's (an acceleration of 22 MPH/sec. or 35 km/h/sec.). Records number of times acceleration exceeded specified limit for each trip. Records number of times deceleration exceeded specified limit for each trip. Accuracy: $\pm 5\%$
Alarms	Audible alarm (optional) for exceeding speed, acceleration, and deceleration limits Visible alarm message for exceeding speed, acceleration, and deceleration limits Driver ID/Location ID code entry reminder alarm (requires software to set)
Distance	Displays and records total distance travelled during current trip in miles or kilometers. Records overall distance (odometer requires software to set). Specifies miles as business, personal, commute, or other. Accuracy: $\pm 1\%$
Time & Date	Displays current date in Month:Day or Day:Month format. Displays current time in 12- or 24-hour format. Records start and end time for each trip. Records total time for each trip. Accuracy: ± 2 seconds/day
Accident Logs (AL)	Records vehicle speed in last 20 seconds before and after deceleration limit exceeded. Stores 10 separate accident logs. Computes and displays driver performance score.
Security	Owner-specified 4-digit password protects settings and data. Tamper indicator message appears if unit is disconnected. Tamper indicator appears if incorrect security password is entered 3 times. Tamper log stores time and date of last 10 tamper alerts. Time and date of each connect and disconnect is recorded.
Sensor Type	VSS input or rugged reed switch sensor with magnet for mounting on vehicle driveshaft (rear wheel drive) or CV joint (front wheel drive).
Lamp	Illuminated display
Primary Power	11 to 18 VDC (12 VDC nominal)
Secondary Power	3-volt CR123 lithium battery (included) allows display unit to be removed from car. Battery operating time is approximately 260 hours when it is disconnected from vehicle.
Digital Inputs	2 digital inputs. Input 1 : green wire; Input 2: yellow wire; Input Impedance 10 Kohms Low: 0.5 V to -0.5 VDC; High: 9.0 to 18.0 VDC
Fuses (Power & Digital Input)	3AG (1 1/4" x 1/4", 6.4mm x 31.8mm), .25A, Slo-Blo
Temperature	Operating range -4° F to 185° F (-20°C to 85°C)
Size	5.25" x 2.25" x 0.86" (132 mm x 57 mm x 22 mm) LCD display size: 3.20" x 1.30" (81 mm x 33 mm)
Display Mounting Options	Visor clip for mounting on visor or door pockets. Double-sided tape for mounting on dashboard and other surfaces. Velcro with pressure-sensitive adhesive for mounting on dashboard and other surfaces. Mounting bracket with right angle adapter for special mounting needs.

DAVIS 
Davis Instruments

3465 Diablo Avenue, Hayward, CA 94545-2778 U.S.A.

510-732-9229 • Fax: 510-732-9188

E-mail: info@davisnet.com • www.davisnet.com