

DriveRight 600E **User's Guide**

Product # 8126GD, 8126HD, 81260BD, 8126VSS, 8179



One Year Limited Warranty

We warrant our products to be free of defects in material and workmanship for one year from date of original purchase. We make every effort to carefully manufacture our products to the highest standards of quality. Occasionally, however, parts may be missing, defective, or damaged.

If you have a defective part, please call 1-510-732-7814 for authorization before returning the item for repair or replacement. Upon receiving authorization, return the product to us, shipping charges prepaid. Include proof of purchase and a written explanation of the problem. During the warranty period, we will, at our option, either repair or replace the product free of charge.

This warranty does not cover damage due to improper installation or use, negligence, accident, unauthorized service, or the incidental or consequential damages beyond the Davis products themselves. Implied warranties are limited in duration to the life of this limited warranty. Some states do not allow limitations on how long an implied warranty lasts, or the exclusion or limitation of incidental and consequential damages, so the above limitations may not apply to you. This warranty gives you specific legal rights. You may have other rights, which vary from state to state.

FCC Part 15 Class B Registration Warning

This equipment has been tested and found to comply with the limits for a Class B digital device, pursuant to Part 15 of the FCC Rules. These limits are designed to provide reasonable protection against harmful interference in a residential installation. This equipment generates, uses, and can radiate radio frequency energy and, if not installed and used in accordance with the instructions, may cause harmful interference to radio communications.

However, there is no guarantee that interference will not occur in a particular installation. If this equipment does cause harmful interference to radio or television reception, which can be determined by turning the equipment on and off, the user is encouraged to try to correct the interference by one or more of the following measures:

- Reorient or relocate the receiving antenna.
- Increase the separation between the equipment and receiver.
- Connect the equipment into an outlet on a circuit different from that to which the receiver is connected.
- Consult the dealer or an experienced radio/TV technician for help.

Changes or modifications not expressly approved in writing by Davis Instruments may void the user's authority to operate this equipment.

© Davis Instruments Corp. 2006. All rights reserved.

DriveRight 600E User's Guide

Rev. A, 7/20/06

Document Part Number: 7395.225

Product Numbers: 8126GD, 8126HD, 8126VSS, 8126OBD, 8179

The information in this manual is subject to change without notice.

This product complies with the essential protection requirements of the EC EMC Directive 89/336/EC and 95/54/EC 'e' Mark.

DriveRight is a registered trademark of Davis Instruments Corp.



3465 Diablo Avenue, Hayward, CA 94545-2778 U.S.A.

510-732-9229 • Fax: 510-732-9188

E-mail: info@davisnet.com • www.davisnet.com

Table Of Contents

Introduction to the DriveRight 600E.....	1
A Note About the Concept of “Trips”	1
DriveRight Fleet Management Software	1
Using the DriveRight 600E	2
Using the Four Buttons	2
DriveRight 600E Screens	2
Data Screens	3
Settings Screens	3
Calibrating the DriveRight.....	4
Calibrating the DriveRight using FMS	5
Calibrating Using the Speedometer	5
Calibrating Using Distance Readings	7
Data Screens	8
Current Readings Screen	8
Driver ID Code Entry & Digital Input Status Screen	10
Trip Start/End Log Screen	11
Trip Speed and Distance Log Screen.....	12
Trip Acceleration/Deceleration Log Screen	13
GPS Latitude and Longitude Position Screens	13
Limits Screen	14
Settings Screens	15
Security Code Screen.....	15
Clear Log Screen	16
Alarm On/Off Screen.....	17
Calibration Screen.....	18
Time Entry	18
Date Entry	19
Year Entry.....	19
Miscellaneous Information	20
Accident Log.....	20
Tamper Log.....	20
Battery Operation.....	20
Battery Life	22
Display Lamp.....	22
Restarting the DriveRight 600E	22
Troubleshooting Guide	23

Technical Specifications	25
Contacting Davis Technical Support	27

Introduction to the DriveRight 600E

The DriveRight 600E, in conjunction with DriveRight Fleet Management Software (FMS), provides advanced vehicle safety and uses monitoring capabilities as well as comprehensive fleet management capabilities. This manual explains how to use the DriveRight 600E to view information and change DriveRight 600E settings.

A Note About the Concept of “Trips”

Much of the data stored and displayed by the DriveRight 600E is stored by “trip.” A trip is the time that has elapsed from when the vehicle first moves to the time the DriveRight device logs a “trip stop time” or a driver “logs out”. For example, the maximum speed and the time spent driving over the set speed limit can be viewed for each trip.

Stored in the DriveRight 600E is a “trip stop time” which represents the amount of time for which the vehicle must be stopped before the DriveRight 600E ends the current trip. The default trip stop time is 10 minutes (this setting may be altered using FMS). Whenever the vehicle is *not in motion* for an amount of time equal to the trip stop time, the DriveRight 600E saves the current trip data to memory and begins a new trip (this new trip remains empty until the vehicle begins moving again). The DriveRight 600E also saves the current trip data whenever a driver “logs out” (see “Driver ID Code Entry & Digital Input Status Screen” on page 10).

DriveRight Fleet Management Software

DriveRight Fleet Management Software (FMS) enables a user to keep track of detailed vehicle information, and provides access to some additional features in the DriveRight 600E device. The following is a list of the DriveRight 600E features which are accessed by using FMS only.

- **View information contained in the “accident log”**
- **View tamper information**
- **Set login alarm**
- **Set trip stop time**
- **Download up to 100 authorized driver ID codes**
- **Set and revise limit settings**
- **View trip type information** — Although you may specify the type of trip using the DriveRight 600E display device, you must have FMS to view trip type information.
- **Configure GPS** — Requires optional DriveRight 600E GPS/Wireless Interface Module (#8127) and GPS Module (#8128).

Using the DriveRight 600E

This section briefly describes the DriveRight 600E display device, the use of the four buttons (PLUS, MINUS, MODE, SET/CLEAR) and the sequence of Data Screens and Settings Screens. Descriptions of the information and options available from each screen are explained separately in “Data Screens” starting on page 8 and “Settings Screens” starting on page 15.

Note: Never attempt to change the DriveRight 600E display while driving. Safe driving requires extreme attentiveness. Changing the DriveRight 600E display while driving may result in dangerous distraction. Only use the device when you are not operating your vehicle. Always warn drivers about the DriveRight 600E's alarms. If an alarm sounds, a driver who has not been warned may be startled or get distracted trying to trace the source of the noise. In either case, it may create a safety concern, so warn drivers in advance.

Using the Four Buttons

The DriveRight 600E has four buttons: PLUS, MINUS, SET/CLEAR, and MODE. The general use of each button is explained briefly below:

- **PLUS (+) and MINUS (-)** — Use PLUS and MINUS to toggle options On or Off, or to scroll through the ten digits possible (0 -9) when entering a number (Usually for entering or setting the Driver ID code, or changing the date and time).

Also, Use PLUS and MINUS to page forward or backward (respectively) through the stored trips or logs.

- **SET/CLEAR** — When entering codes or setting limits, the flashing digit/segment indicates what will change if PLUS or MINUS is pressed. Pressing and releasing SET/CLEAR causes the next digit/segment to flash.

From the Driver ID Code screen, press and hold SET/CLEAR (for at least 2 seconds) to “log out.” The Driver ID code is reset to 0000.

In the Current Readings screen, press and hold SET/CLEAR for 2 seconds to toggle between the two available units of measure (mph and KM).

In the Date Entry and Time Entry screens, press SET/CLEAR until the entry flashes and use PLUS and MINUS to scroll through the options.

- **MODE** — Press and release MODE to move to the next data or information screen. Press and hold MODE to switch between the Data Screens and the Settings Screens. When the DriveRight is in sleep mode, press MODE to “wake” it up.

DriveRight 600E Screens

The DriveRight 600E contains several screens for viewing and navigating the stored data (Data Screens) and screens for changing and updating the DriveRight 600E settings (Setting Screens).

Data Screens

The data screens display most of the information stored in the DriveRight 600E device. To cycle through the data screens (in the order shown below), press and release MODE several times.

The GPS Latitude and Longitude screens are not displayed if the DriveRight device is not connected to a vehicle with corresponding GPS module or if the device has not been configured to log GPS data via FMS.

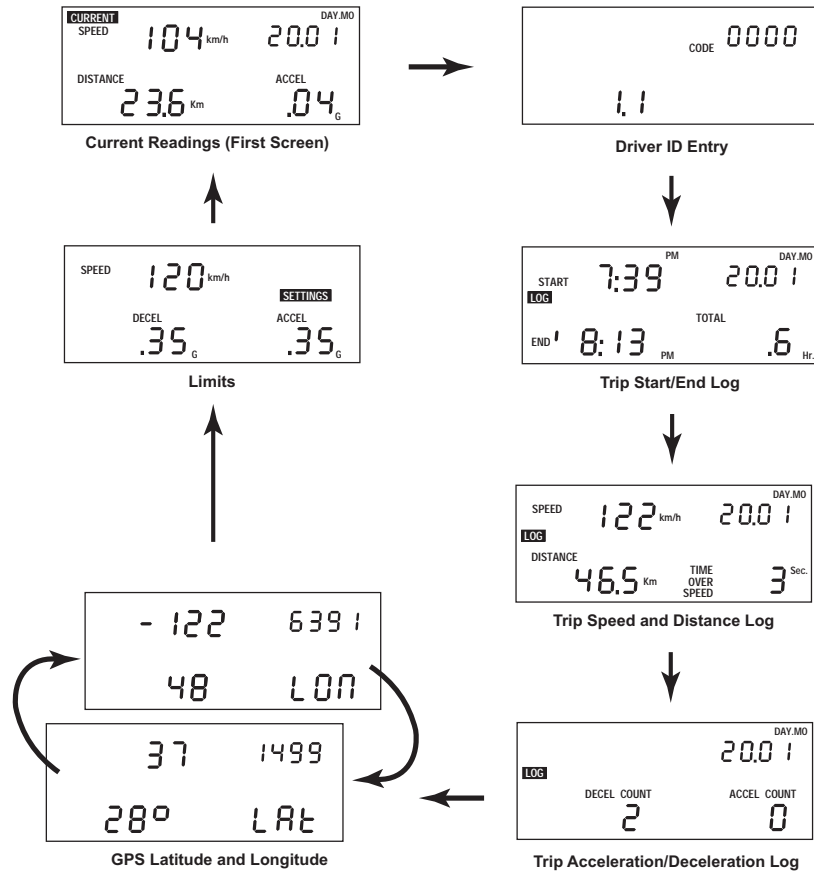

DriveRight 600E Data Screens

Settings Screens

Press and hold MODE in any of the Data Screens to view the Settings Screens. After a few seconds, the Security Code Screen displays. To cycle through the settings screens (in the order shown below), press and release MODE.

Note: To exit the Settings Screens and view the Data Screens, press and hold MODE until the Current Readings screen displays.

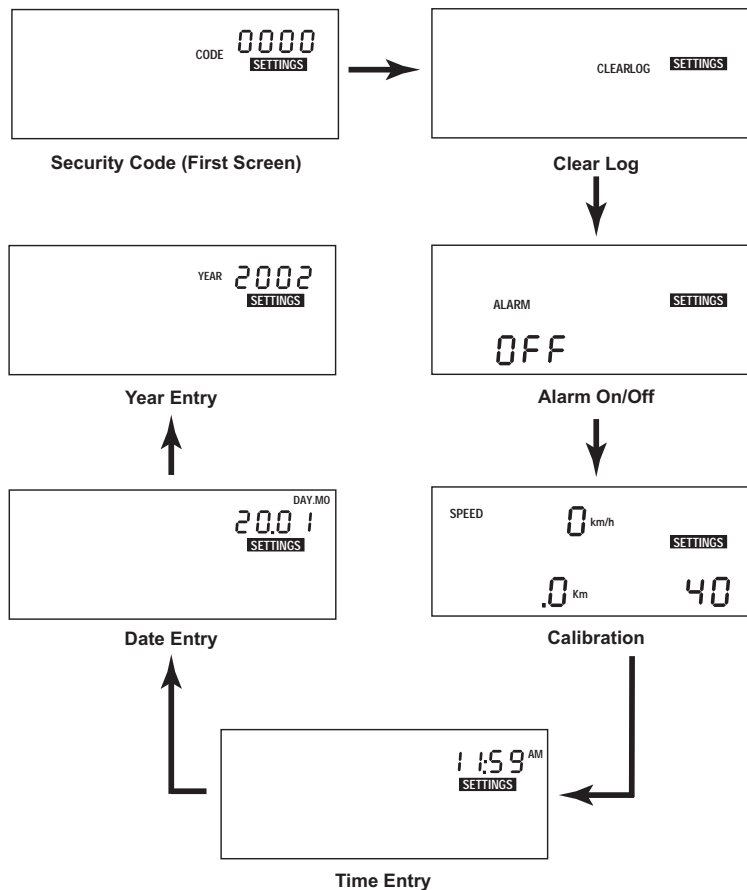

DriveRight 600E Settings Screens

Calibrating the DriveRight

Once the DriveRight is installed in a vehicle, calibrate the device so that it reports the correct speed, distance, deceleration, and acceleration. All General Duty and Heavy Duty (8126GD and 8126HD) versions of DriveRight 600E should be calibrated using the speedometer (see “Calibrating Using the Speedometer” on page 5), or by using the distance reading (see “Calibrating Using Distance Readings” on page 7).

The VSS version (8126VSS) of the DriveRight 600E should be calibrated if vehicle’s VSS pulses per mile is different from the DriveRight 600E’s default

of 4000 pulses per mile, or if the vehicle's pulses per mile are not known. VSS versions should be calibrated using the speedometer (see "Calibrating Using the Speedometer" on page 5), or by using the distance reading (see "Calibrating Using Distance Readings" on page 7) or, if the vehicle's pulses per mile reading is known, can be calibrated using FMS.

DriveRight 600E OBD (8126OBD) requires no calibration. Select the OBD installation method when you add a DriveRight 600E OBD to DriveRight FMS.

Note: Enter the DriveRight security code before calibrating the DriveRight 600E. See "Security Code Screen" on page 15 for more information.

Calibrating the DriveRight using FMS

Use FMS to accurately calibrate the DriveRight 600E VSS device, provided you know the pulses per mile used by your vehicle's VSS (vehicle speed sensor). Contact your dealer's service department for the pulses per mile used by your vehicle's VSS. Instructions on calibrating the DriveRight 600E using FMS can be found in the FMS Online Help.

Calibrating Using the Speedometer

To calibrate using the DriveRight 600E's speedometer, drive steadily at 40 km/h (25 MPH) and press a SET/CLEAR on the DriveRight 600E. The DriveRight 600E bases its calibration on the speed of the vehicle at the moment of calibration which it assumes to be 40 km/h (25 MPH). Because of the nature of this calibration procedure, Davis Instruments strongly recommends that it be performed by two people: one to drive the vehicle and one to operate the DriveRight 600E.

Note: If the DriveRight security code is protected, enter the code number. The DriveRight does not grant access to the Calibration Screens until the security code is entered.

1. Press and hold MODE to access the Settings Screens.
2. Enter the security code in the Security Code Screen.
3. Press and release MODE until the Calibration Screen displays.

The calibration speed (40 or 25) is located at the bottom right of the display. The uncalibrated speed reading is located at the top of the display, along with the unit of measure (km/h or MPH). Until the DriveRight 600E is calibrated, this speed reading will be inaccurate. The distance, which appears in the lower left of the display, is not necessary for this calibration procedure.

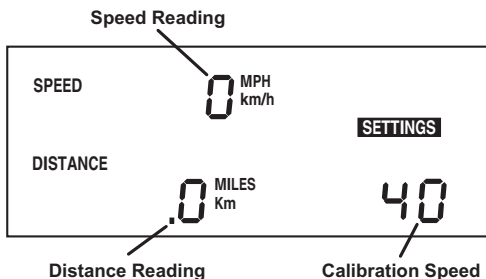

Calibration Screen

4. Drive the vehicle until it reaches 40 km/h (25 MPH) and keep the vehicle steady at that speed.
5. Press and hold SET/CLEAR once the vehicle is moving steadily at the calibration speed.

The word CAL appears in the top right of the display. This indicates that the DriveRight is in the process of calibrating.

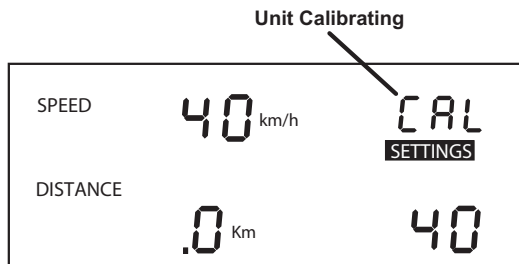

Unit Calibrating

6. Continue to hold SET/CLEAR until the DriveRight beeps and the word "DONE" appears on the display. The DriveRight has finished calibrating. The speed reading at the top of the display also changes so that it reads much closer to the vehicle's speedometer reading.

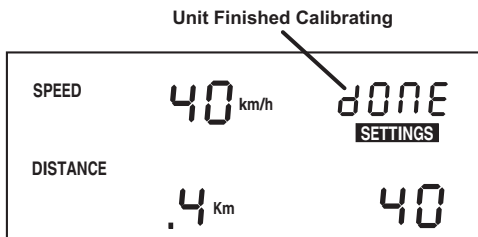

Unit Finished Calibrating

7. Once the calibration is complete, drive the vehicle and compare the vehicle's speedometer to the DriveRight 600E's speed display.

Be aware that the DriveRight 600E responds to changes in speed faster than most vehicles' speedometers. To accurately compare, drive steadily at one speed for a short time.

8. Fine tune the calibration by pressing PLUS or MINUS.

Each time PLUS or MINUS is pressed, the DriveRight 600E speed reading adjusts up or down. Depending on the speed of the vehicle and of the calibration, a change in the speed reading in the Calibration Screen may or may not display each time a button is pressed.

Note: Pressing and holding PLUS or MINUS down increases the rate at which the DriveRight 600E adjusts the speed reading.

9. Continue to press PLUS or MINUS until the DriveRight 600E's speed reading agrees with the vehicle's speedometer *at a variety of speeds*.

10. When finished calibrating, press and hold MODE until the Current Readings Screen displays. All calibration information is automatically saved.

Note: Do not press and hold SET/CLEAR in an effort to save the fine-tuned calibration. The DriveRight completely resets the calibration number if SET/CLEAR is pressed.

Calibrating Using Distance Readings

To calibrate using the vehicle's distance reading instead of its speed readings, compare a distance reading taken from the vehicle's odometer to the DriveRight 600E distance reading and adjust the DriveRight 600E to match the vehicle's odometer.

Note: Davis Instruments recommends that you drive a minimum of 32km (20 miles) when calibrating the DriveRight using its distance reading.

The vehicle's speedometer and odometer may not be perfectly linked. If the two readings differ and the DriveRight 600E has been calibrated using the vehicle's odometer, a discrepancy between the DriveRight 600E's speed readings and the vehicle's speedometer may exist.

1. Obtain a rough calibration, using the speedometer as described in "Calibrating Using the Speedometer" on page 5.
2. Reset the vehicle's trip meter to zero or note the odometer reading.
3. Start a new trip on the DriveRight 600E (i.e., the distance travelled is 0) and make sure the Current Readings Screen is being displayed.

To forcibly start a new trip, log out (see page 11 for details).

4. Drive the vehicle for at least 32 km (20 miles). The calibration becomes more accurate the further the vehicle is driven.
5. When finished driving, compare the vehicle's distance reading to the distance reading on the DriveRight 600E.

6. Increase or decrease the distance measured by the DriveRight 600E until it agrees with the vehicle's odometer reading. This is accomplished from the Calibration Screen.
7. Press and hold MODE to access the Settings Screens.
8. Press and release MODE until the Calibration Screen displays.

The distance travelled appears at the lower left of the display. Note that until the DriveRight 600E is calibrated, this distance reading is inaccurate. The speed reading and calibration speed, which appear on the display as well, are not necessary for this calibration process.

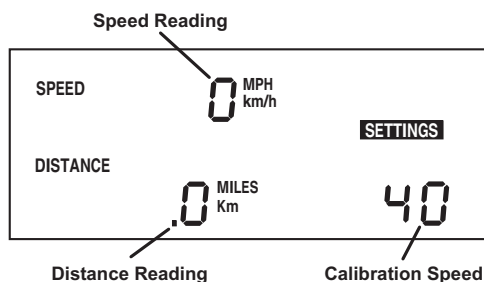

Calibration Screen

9. Press PLUS or MINUS until the distance reading matches the distance on the vehicle.

Note: Pressing and holding PLUS or MINUS increases the rate at which the DriveRight 600E adjusts the distance reading.

10. When finished calibrating, press and hold MODE until the Current Readings Screen displays. All calibration information is automatically saved.

Note: Do not press and hold SET/CLEAR in an effort to save the fine-tuned calibration. The DriveRight device completely resets the calibration number if SET/CLEAR is pressed.

Data Screens

The following section explains all the information and options available in the Data Screens. In addition to the options listed in the individual sections below, the following two options are available in every screen:

- **Move to the next Data Screen** — Press and release MODE.
- **View the Settings Screens** — Press and hold MODE.

Current Readings Screen

The Current Readings Screen displays constantly updating (when the vehicle is moving) speed, distance (for the current trip), and acceleration/deceleration

readings (acceleration is positive, deceleration is negative). The current date (or time) is also displayed on this screen.

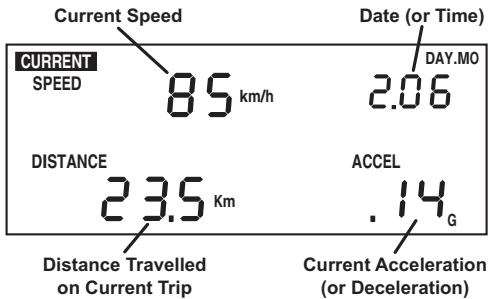

Current Readings Screen

The following options are available in the Current Readings Screen:

- **Toggle Between Date and Time Display** — To display either the date or the time, press and release SET/CLEAR.
- **Change Units of Measure Displayed** — To change the units of measure in which the data is displayed from metric to U.S. units (or vice versa), press and hold SET/CLEAR for approximately 2 seconds. This does not change the date or time display format.
- **Specify Trip Type** — There are four types of trips stored by the DriveRight 600E: Business, Personal, Commute, and Other. The trip type is stored along with the rest of the trip information and is automatically saved when information is downloaded using FMS.

To change the type of trip, press and hold MINUS. The Trip Type Screen displays and scrolls through the four options. Do not release MINUS. The DriveRight 600E scrolls through the letters representing the various trip types: b = Business, P = Personal, C = Commute, O = Other. Release MINUS when the desired trip type displays. The trip type can be changed anytime during the trip. Trip type information is saved when the trip ends.

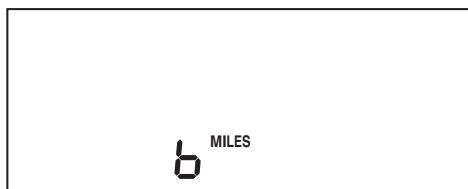

Trip Type Screen

Note: Although trip type can be specified using the DriveRight 600E display device, FMS must be used to view the trip type for each trip.

-
- **Turn Display Lamp On/Off** — To turn the DriveRight 600E's display lamp on or off, press PLUS. View the Current Readings Screen, or the GPS screen to turn the display lamp on and off.
-

Note: The lamp does not turn off if the vehicle is in motion. The lamp automatically turns off once the log out time has elapsed.

Driver ID Code Entry & Digital Input Status Screen

Enter the Driver ID Code in the Driver ID Code Entry Screen to display the status of the two digital inputs, and view an activity indicator for the reed switch (GD and HD models) or VSS input (VSS model).

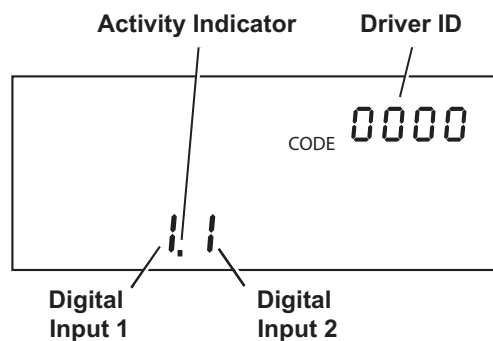

Driver ID Code Entry Screen

Driver ID Code

When using the DriveRight 600E to monitor multiple drivers, assign each driver a unique 4-digit ID code. Before driving the vehicle, the driver must enter his or her ID code. Manual entry of the Driver ID can be disabled using FMS if the SmartCard On-Board Reader (#8105) is being used to log drivers in and out of the vehicle.

The DriveRight 600E stores the Driver ID Code with the rest of the trip information. Data downloaded to FMS is segregated by Driver ID Code, enabling detailed tracking of multiple drivers. If the Drive ID Code is set for a single user, Location IDs can be identified using FMS (see FMS Online Help for more information). Also, use FMS to turn on an alarm which will alert the driver when a driver ID (or location ID) has not been entered.

Note: Driver ID code 0000 (four zeros) is used to view information for the vehicle (all drivers) and should not be assigned to any driver.

In addition to marking data as belonging to a particular driver, the driver ID code may be used on the device to filter the information being viewed. To view information for one specific driver, enter that driver's ID code in this screen. The DriveRight 600E display filters out any data not assigned that code. To view all information, regardless of Driver ID Code, enter 0000.

The following options are available in the Driver ID Code Entry Screen:

- **Enter a Driver ID Code** — When the Driver ID Code Entry Screen is first displayed, the first digit to the left flashes, indicating that it is the active digit. Press and release PLUS or MINUS to cycle forward or backward through the available entries for the active digit (0 to 9). To change the digit which is active, press and release SET/CLEAR. The digits are cycled through each time SET/CLEAR is pressed.

Only the Driver ID codes that have been programmed into the DriveRight 600E are accepted. A "NO" displays on the screen if a wrong ID code is entered. A code of "0000" is still accepted.

- **Log Out**—Press and hold SET/CLEAR for 2 seconds, until the code resets to 0000. As soon as a driver logs out, the current trip is ended and data for that trip is stored in the DriveRight 600E's memory. Do not log out when the vehicle is in motion.

Two Digital Inputs

Two digital inputs are available on the DriveRight 600E that track the operation of lights or other electrically powered accessories on the vehicle. A typical application would be to monitor the headlights and the brakes. The screen displays "1" if the input is high, and "0" if the input is low. The status of the inputs is stored in the trip log.

Activity Indicator

Primarily useful for troubleshooting the installation, the small "dot" between the two activity indicators displays whenever the reed switch used with the General Duty (8126GD) and Heavy Duty (8126HD) models is closed, or whenever the VSS input used with the 8126VSS models is high. The reed switch closes once each time the vehicles drive shaft rotates.

Trip Start/End Log Screen

The Trip Start/End Log Screen shows the start and end time for each trip currently stored in the DriveRight 600E's memory. To view trip times for a specific driver, enter that driver's ID code in the Driver ID Code Entry Screen. To view all trip times for the vehicle, enter ID code 0000.

Note: If the end time for a trip is "dashed," it means that the current trip is being viewed, which has not yet ended (unless the DriveRight was restarted in the middle of a trip)

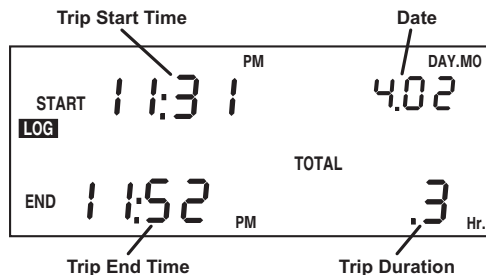

Trip Start/End Log Screen

The following option is available in the Trip Start/End Log Screen:

- Page Through Stored Trip Information** — Press MINUS to page backward through stored trip information. Press PLUS to page forward through stored trip information. Hold the button to increase the paging speed. The DriveRight 600E stops paging in the selected direction once it reaches the first or last trip.

Trip Speed and Distance Log Screen

The Trip Speed and Distance Log Screen shows the maximum speed, distance travelled, and amount of time spent driving over the set speed limit for each trip currently stored in the DriveRight 600E's memory.

To view trip speed and distance information for a specific driver, enter that driver's ID code in the Driver ID Code Entry screen. To view all trip speed and distance information for the vehicle, enter Driver ID Code 0000.

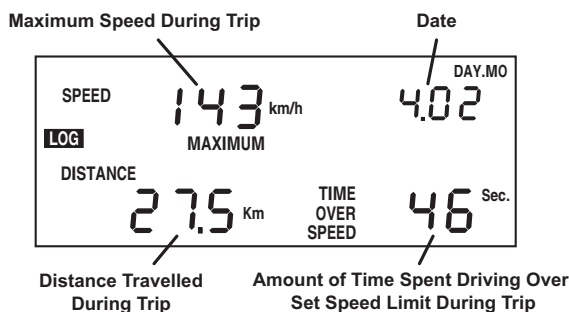

Trip Speed and Distance Log Screen

The following option is available in the Trip Speed and Distance Log Screen:

- **Page Through Stored Trip Information** — Press MINUS to page backward through stored trip information. Press PLUS to page forward through stored trip information. Hold the button down to increase the paging speed. The DriveRight 600E stops paging in the selected direction once it reaches the first or last trip.

Trip Acceleration/Deceleration Log Screen

The Trip Acceleration/Deceleration Log Screen shows the number of times the set acceleration and deceleration limits were exceeded during each trip currently stored in the DriveRight 600E's memory. Each time the limit is exceeded, 1 "count" is recorded, regardless of the amount of time the limit was exceeded.

To view trip acceleration/deceleration information for a specific driver, enter that driver's ID code in the Driver ID Code Entry Screen. To view all trip acceleration/deceleration information for the vehicle, enter ID code 0000.

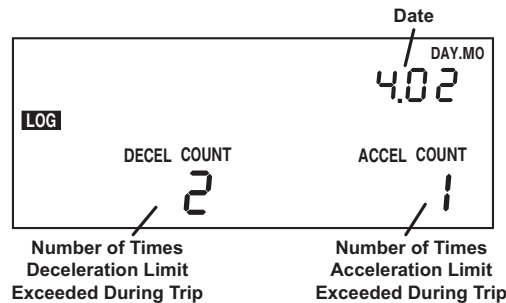

Trip Acceleration/Deceleration Log Screen

The following options are available in the Trip Acceleration/Deceleration Log Screen:

- **Page Through Stored Trip Information** — Press MINUS to page backward through stored trip information. Press PLUS to page forward through stored trip information. Hold the button to increase the paging speed. The DriveRight 600E stops paging in the selected direction once it reaches the first or last trip.

GPS Latitude and Longitude Position Screens

The GPS Position Screens alternate between Latitude and Longitude to show the vehicle's current position, speed, and direction.

Note: The GPS screens are not displayed if the DriveRight device is not connected to a vehicle with corresponding GPS module or if the device has not been configured to log GPS data via FMS.

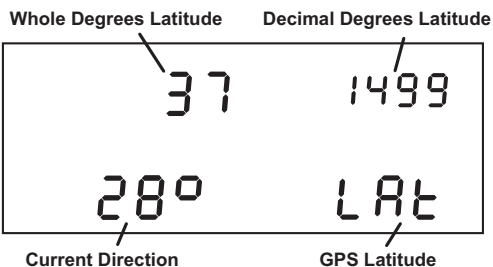

Latitude Screen

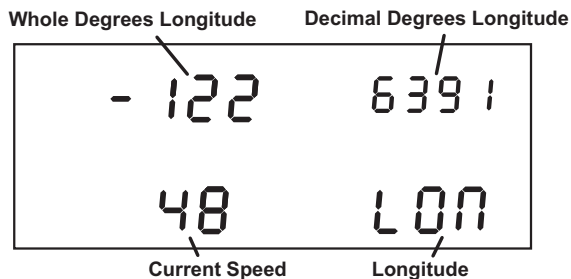

Longitude Screen

A “NO” on the Latitude and Longitude screens indicates the GPS module is not able to track your current position. The last known position is displayed.

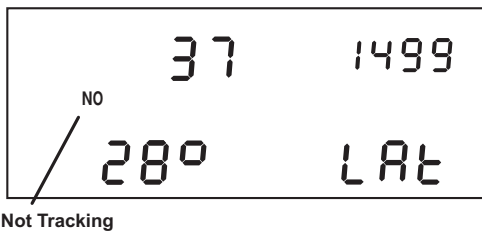

Not Tracking Indicator

Note: The GPS may take up to several minutes to start tracking a new trip, depending on the overhead obstructions near the vehicle.

Limits Screen

The Limits Screen displays the set speed, acceleration, and deceleration limits for the DriveRight 600E. None of the limits can be changed from this screen. The limits can only be changed using FMS.

Acceleration and deceleration is measured in “G’s” (the gravitational constant which represents the acceleration of an object when falling to earth in a vacuum). 1G is roughly equal to an acceleration of 35 km/h (22 MPH) per second.

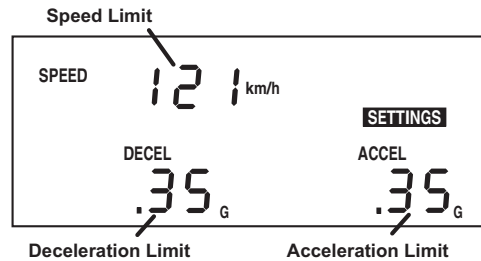

Limits Screen

Settings Screens

The following section explains all the information and options available in the various Settings Screens. In addition to the options listed in the individual sections below, the following two options are available in every screen:

- **Move to the next Settings Screen** — Press and release MODE.
- **View the Data Screens** — Press and hold MODE.

Security Code Screen

If you are concerned about unauthorized changing of DriveRight 600E settings, enter a security code from the DriveRight or FMS. After entering the security code, the DriveRight 600E does not allow access to the rest of the settings screens until the correct 4-digit security code is entered. The DriveRight allows five attempts to enter the correct security code before returning to the Current Readings Screen and activating the tamper indicator (pressing MODE to move to the next settings screen is considered an “attempt”). The time and date of the unsuccessful tamper attempt are stored and may be viewed using FMS.

Note: Use security code 0000 (four zeros) to keep the settings and calibration from being password-protected, since the DriveRight defaults to that code when first displaying the Security Code Screen.

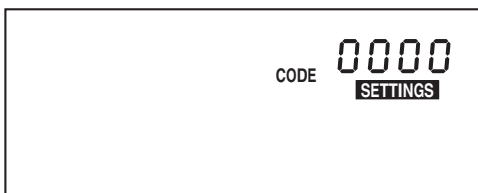

Security Code Screen

The following options are available from the Security Code Screen:

- **Enter the Security Code** — The flashing digit in the code is the active digit. Press and release PLUS or MINUS to cycle forward or backward through the available entries for the active digit (0 to 9). To change the active digit, press and release SET/CLEAR. Each time SET/CLEAR is pressed, the next digit becomes active. Once the correct security code has been entered, press MODE to move to the next settings screen.

Note: If the entered code is correct, the Clear Log Screen displays. If the entered code is not correct, the word NO displays. The correct code may be attempted five times before the DriveRight returns to the Current Readings Screen and activates the tamper indicator, if the tamper indicator is enabled. See the FMS Online Help for more information.

- **Set or Change the Security Code**—Use PLUS and MINUS to enter the current correct code, if entering the security code for the first time, make sure 0000 is entered,. Press and hold SET/CLEAR until the word “CHG” (change) displays:

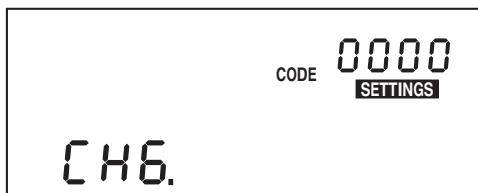

Change Security Code

Use PLUS and MINUS to enter the new desired security code and make a note of the new security code. When finished, press MODE to save the new code and move to the Clear Log Screen.

Clear Log Screen

The Clear Log Screen may be used to perform a “total clear” function which erases all data for every trip in your log at once.

Note: All the stored trips for every driver are cleared using this screen.

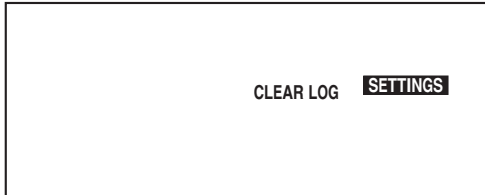

Clear Log Screen

Note: Accident and tamper log data cannot be cleared using this screen.

The following option is available in the Clear Log Screen:

- **Clear all Log Data** —Press and hold SET/CLEAR. The word “CLR” (clear) appears in the display to indicate that the DriveRight is preparing to clear all log data. To protect against accidental clearing of data, press and hold SET/CLEAR for 3 seconds to clear the data.



Preparing to Clear Log Data

Continue to hold SET/CLEAR until the DriveRight beeps and the word “CLR” disappears from the display. This indicates that the DriveRight is in the process of clearing data. The DriveRight beeps and the word “DONE” appears in the display when the DriveRight finishes clearing data.



DriveRight Finished Clearing Data

Alarm On/Off Screen

The Alarm On/Off Screen toggles the DriveRight 600E’s audible alarm on and off. When the alarm is on, the DriveRight beeps when any of the set limits are exceeded, warning the driver of the violation. Turning the alarm off disables

the beeping, though the DriveRight 600E continues to record violations of the set limits.



Alarm On/Off Screen

The following option is available in the Alarm On/Off Screen:

- **Toggle the Alarm Setting** — Press and release SET/CLEAR to toggle the alarm setting from On to Off (or vice versa). Each time SET/CLEAR is pressed, the display changes between “ON” and “OFF”.

Calibration Screen

The Calibration Screen calibrates the DriveRight 600E for the desired vehicle. See “Calibrating the DriveRight” on page 4 for details.

Time Entry

The Time Entry Screen enables you to set the time and to select the format (12 hour or 24 hour) in which you want time displayed.



Time Entry Screen

The following options are available in the Time Entry Screen:

- **Set the Time** — Press PLUS and MINUS to toggle through the digits for each segment on the time display. Press SET/CLEAR to move through each segment on the time display. Press SET/CLEAR until the time format flashes. Press PLUS or MINUS to toggle through the three available options: “AM”, “PM”, or “24HR”. If the time entered is in the 12 hour format, remember to select either AM or PM.
- **Change the Time Display Format** — Press and release SET/CLEAR until the “AM”, “PM”, or “24HR” segment is flashing. Press PLUS to cycle through the three possible options. When the desired option appears in the display, stop. The segment displayed when MODE is pressed to exit this screen sets the format that is displayed.

Note: The DriveRight does not automatically convert the time from 12 hour to 24 hour or vice versa. Enter the time in the new format manually.

Date Entry

The Date Entry Screen allows you to set the date and to select the format (Day:Month or Month:Day) in which the date is displayed.



Date Entry Screen

The following options are available in the Date Entry Screen:

- **Set the Date** — Press PLUS and MINUS to toggle through the numbers for each segment. Press SET/CLEAR to move through each digit.
- **Change the Time Display Format** — Press and release SET/CLEAR until the “MO:DAY” (Month:Day) or “DAY.MO” (Day:Month) segment is flashing. Press PLUS to toggle between the two segments. When the desired format appears in the display, stop. The segment displayed when MODE is pressed to exit this screen is the format in which the date is displayed.

Year Entry

The Year Entry Screen allows you to enter the correct year, which lets the DriveRight automatically adjust for leap years.

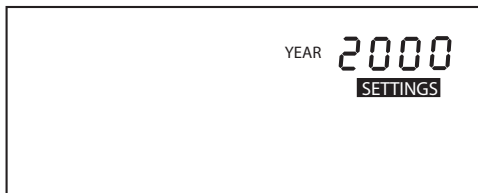

Year Entry Screen

The following option is available in the Year Entry Screen:

- **Set the Year** — Press PLUS and MINUS to toggle through the numbers for each segment. Press SET/CLEAR to move through each digit.

Miscellaneous Information

Accident Log

The DriveRight 600E has memory enough for 10 “accident” logs which show the vehicle’s speed for the 20 seconds before and after a sudden deceleration. Data is written to the “accident” log any time the vehicle exceeds the DriveRight’s set deceleration limit. Also, the last 20 seconds of trip information for each of the last 20 trips is saved in the accident log.

The information in the accident log may be downloaded, viewed, printed, and stored using FMS.

Tamper Log

The following actions are logged as a tamper attempts:

- The DriveRight 600E is unplugged (loses power.)
- Five incorrect entries in a row in the Security Code Screen.
- DriveRight is plugged back into the vehicle (a tamper is logged but not displayed on the device).
- DriveRight is rebooted.

When a tamper is logged, “TAMPER” displays on all screens if the tamper light has been enabled using FMS. The time at which the tamper attempt occurred and the cause of the tamper are also stored in the tamper log. The last 10 tamper events can be downloaded, viewed and printed, using FMS.

To clear the flashing TAMPER segment, enter the correct security code (see “Security Code Screen” on page 15). The tamper indicator is also cleared after data is downloaded.

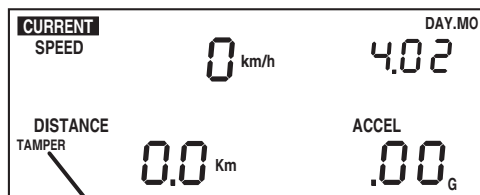

Tamper Indicator Flashing

Tamper Indicator (Current Readings Screen)

Note: All data in the DriveRight 600E is stored in “non-volatile” memory which means no data is lost even if power is removed.

Battery Operation

The DriveRight 600E is designed to be taken out of your vehicle so the data may be reviewed anywhere. When the DriveRight is disconnected from the vehicle (its primary power source), it automatically switches to battery power.

The word “BAT” displays in the lower left corner of all screens to indicate that the DriveRight is currently running on battery power.

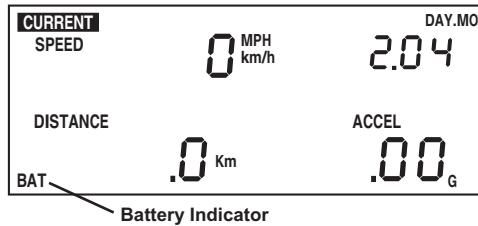

Battery Power Indicator

Note: If the LCD display fades when running on battery power, the battery power is low. Replace the battery as soon as possible.

To install a new battery, insert the battery as shown below.

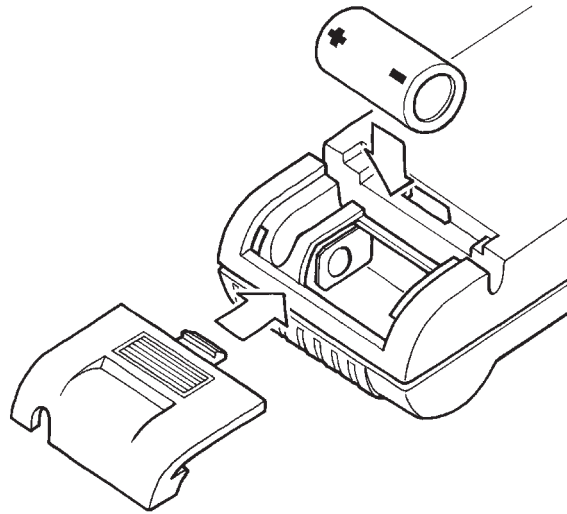

Installing the Battery

A low battery can be replaced without losing the time or date settings, if it is replaced within 20 seconds of the old battery being taken out. If the old battery has a complete loss of power before it is replaced, make sure to check the time and date settings once power has been restored.

When operating under battery power, the DriveRight undergoes a few changes in operation to conserve battery power:

- If it has been 5 minutes since a button was pressed, the DriveRight enters “sleep mode.” In sleep mode, all but the most essential DriveRight functions (that is, time and date) are shut down. The display goes blank and no data is recorded when the DriveRight is “asleep.”
To “wake up” the device, press MODE or reconnect the device to a vehicle so it receives power from the vehicle’s battery.

Note: The DriveRight never goes into sleep mode when connected to the vehicle (i.e., receiving power from your vehicle’s battery).

- The display lamp is disabled.
- The GPS Latitude and Longitude Position Screens are not displayed. The Latitude and Longitude Screens do not display when scrolling through the DriveRight 600E Data Screens.

Battery Life

When removed from a vehicle, the DriveRight taps into its own battery for power (instead of relying on the vehicle’s battery). A DriveRight can operate for 260 hours or up to 4 months in sleep mode on battery power alone.

The life of the battery depends on the download schedule. For example, if the DriveRight is taken out of the vehicle 5 days a week, 8 hours a day, the battery can last up to 16 months. In that situation, because not all out-of-vehicle time will be spent in sleep mode and because of the occasional delay in returning the DriveRight to the vehicle, Davis Instruments recommends replacing the battery every year. If at any time the LCD display begins dimming, the battery is low and due for replacement.

If storing a DriveRight out-of-vehicle for more than a week, Davis Instruments recommends removing the battery. When the battery is replaced, data and settings are not lost but the date and time need to be reset.

Display Lamp

To read the DriveRight 600E at night, use the display lamp. To toggle the display lamp on and off, press PLUS when viewing the Current Readings screen. The display lamp does not work when the DriveRight is operating on battery power.

Note: The display lamp automatically shuts itself off once the logout time has elapsed.

Restarting the DriveRight 600E

If the DriveRight 600E is locked up, remove and re-insert the battery. If done within 20 seconds, the time and date settings will not be lost. Any time the

DriveRight is restarted by removing and reinserting the battery, a tamper is logged.

Troubleshooting Guide

While the DriveRight 600E is designed to provide years of trouble-free operation, occasional problems may arise. If you are having a problem with your DriveRight, please check the following guide before calling the factory. You will be able to solve many of the problems yourself. If, after checking this guide, you are still unable to solve the problem, please contact Davis Instruments technical support. See “Contacting Davis Technical Support” on page 27 for more information. You may also check the support section of our website (www.davisnet.com) or send e-mail to tech support (support@davisnet.com).

Note: Please do not return your DriveRight for repair without prior authorization.

Many of the troubleshooting suggestions below relate to the positioning of the magnet and reed-switch speed sensor used only by the DriveRight 600E General Duty and DriveRight 600E Heavy Duty models.

Note: Davis Instruments is glad to answer any questions you may have regarding the operation of the DriveRight device. Davis Instruments cannot, however, answer any questions relating to the installation of the DriveRight in your vehicle.

- I can't turn the LCD lamps on or off.
Make sure the Current Readings Screen is displayed when PLUS is pressed.
- When operating on batter power, the LCD segments are faint.
Battery power is low. Replace the battery (see “Battery Operation” on page 20).
- The BAT segment is on when the DriveRight is plugged into the vehicle.
The DriveRight is not getting primary power from the vehicle's battery. Check the fuse in the power line in the vehicle.
- The alarm's buzzer is faint or not audible when the DriveRight is operating on battery power.
The alarm is not used when the DriveRight is not connected to a vehicle.
- My DriveRight 600E and my speedometer do not agree.
In the Calibration Screen, use the PLUS and MINUS keys to fine-tune the calibration. See “Calibrating the DriveRight” on page 4 for information.
- My speed is intermittently reading zero while driving (For 8126HD and 8126GD installation types).
This could be one of two things. First, make sure the speed sensor is within 10-16 mm (3/8"- 5/8") of the magnet. If it is, make sure the installed speed sensor protrudes at least 20 mm (3/4") from the bracket.

- My speed reads zero while driving.
There could be a number of things wrong. Make sure the DriveRight 600E is plugged in. Make sure the DriveRight 600E is calibrated. For 8126HD and 8126GD installation types, make sure the speed sensor is within 10-16 mm (3/8" - 5/8") of the magnet. Make sure the DriveRight is not running on battery power (see "Battery Operation" on page 20). If it is check the fuse in the power line. If all of this fails to solve the problem, consult the troubleshooting section of your Installation Guide.
- The speed reading on the DriveRight 600E agrees with my vehicle's speedometer, but the distance reading on the DriveRight 600E and my odometer differ (or vice versa).
For best accuracy, calibrate using the vehicle's odometer (see "Calibrating Using Distance Readings" on page 7). Use the PLUS and MINUS buttons to readjust the distance reading to match the vehicle's trip meter reading periodically, to maintain accuracy.
- The DriveRight 600E seems to be recording erroneous readings at low speeds.
Excessive mechanical vibrations at low speeds can cause erroneous readings in GD and HD models. Have the installation checked if this problem keeps occurring.
- The DriveRight 600E indicates erroneous decelerations at low speeds (VSS models only).
On some vehicles, the wrong dip switch settings can cause the DriveRight 600E's speed reading to abruptly drop to zero at around 10 to 13 mph, which generates an erroneous deceleration log. Check the VSS cable dip switch settings if this problem occurs.
- The display is black or all the segments appear to be on.
The display was left in direct sunlight. The display will return when it cools down. Even though the display is black, the DriveRight 600E continues to record data.
- The tamper light won't go off.
Enter your security code (see "Tamper Log" on page 20).
- I've forgotten my security code.
Read the vehicle's code settings using FMS (see FMS online Help for details). Otherwise, ship the DriveRight back to us with a check for \$25.00 and a note explaining the situation. Davis Instruments returns the DriveRight to you with the code set to 0000.

Technical Specifications

Check our website for updated specifications: www.davisnet.com.

General

Sensor Type	OBDII input, VSS input or rugged reed switch sensor with magnet for mounting on vehicle driveshaft (rear wheel drive) or CV joint (front wheel drive).
Lamp:	Illuminated display
Primary Power	11 to 18 VDC (12 VDC nominal)
Secondary Power	3-volt CR123A lithium battery (included) allows DriveRight to be removed from vehicle.
Battery operating time	260 hours when it is disconnected from vehicle. Battery life is up to four months in sleep mode.
Digital Inputs	2 digital inputs. Input 1: green wire; Input 2: yellow wire
Input Impedance:	>1 Megaohm
High input range:	3 VDC min, system voltage max
Low input range:	-0.5 min to 1.0 VDC max
Input 1 Sampling:	Start and stop of trip, GPS record, Accident Log
Input 2 Sampling:	Start and stop of trip, GPS record
Input power requirements:	12 VDC nominal
Fuses (3):	3AG, 0.25A, Slo-Blo (1 1/4" x 1/4", 6.4 x 31.8mm)
Fuses (Power & Digital Input)	3AG (1 1/4" x 1/4", 6.4mm x 31.8mm), 0.25A, Slo-Blo
Temperature	Operating range -4° F to 185° F (-20°C to 85°C)
Size:	5.25" x 2.25" x 0.86" (132 mm x 57 mm x 22 mm)
LCD display size:	3.20" x 1.30" (81 mm x 33 mm)
Display Mounting Options	Visor clip for mounting on visor or door pockets. Double-sided tape for mounting on dashboard and other surfaces. Velcro with pressure-sensitive adhesive for mounting on dashboard and other surfaces. Mounting bracket with right angle adapter for special mounting needs.
Security	Owner-specified 4-digit password protects settings and data. Tamper indicator message appears if DriveRight is disconnected. Tamper indicator appears if incorrect security password is entered 5 times. Tamper log stores time and date of last 10 tamper alerts. Time and date of each connect and disconnect is recorded.

Speed

Display:	Current speed in MPH or km/h. Records maximum speed for each trip. Records total time in which speed exceeded set limit for each trip.
Accuracy:	±1%

Acceleration and Deceleration

Displays: In G's (an acceleration of 22 MPH/sec. or 35 km/h/sec.). Records number of times acceleration exceeded specified limit for each trip. Records number of times deceleration exceeded specified limit for each trip.

Accuracy: $\pm 5\%$

Alarms

Audible alarm (optional): For exceeding speed, acceleration, and deceleration limits

Visible alarm message: For exceeding speed, acceleration, and deceleration limits

Code entry reminder alarm: Requires FMS to set

Distance

Displays: Total distance travelled during current trip in miles or kilometers.

Records: Overall distance.

Specifies miles as: Business, personal, commute, or other.

Accuracy: $\pm 1\%$

Time & Date

Displays: Current date in Month:Day or Day:Month format. Displays current time in 12- or 24-hour format. Records start and end time for each trip. Records total time for each trip.

Accuracy: ± 2 seconds/day

Accident Logs

Records Vehicle speed in last 20 seconds before and after deceleration limit exceeded. Stores 10 separate accident logs. Stores last 20 seconds of each of the last 20 trips.

Contacting Davis Technical Support

If you have questions, or encounter problems installing or operating your DriveRight 600E, please contact Davis Technical Support. Most questions can be answered while you're on the phone. Sorry, Davis Instruments is unable to accept collect calls.

Note: Please do not return items to the factory for repair without prior authorization.

- **(510) 732-7814** – Monday through Friday, 7:00 a.m. to 5:30 p.m. Pacific Time.
- **(510) 670-0589** – Fax to Technical Support.
- **support@davisnet.com** – E-mail to Technical Support.
- **info@davisnet.com** – E-mail to Davis Instruments.
- **www.davisnet.com** – Product documentation is available on the DriveRight Support section of our website. Watch for FAQs and other updates.

Notes: